

THE PODIUM MUSIC STAND

1 Set Assembly Instructions

Wooden Parts:

- a. 1 Column
- b. 2 Long Slide Pieces
- c. 2 Slide Spacers
(1 long & 1 short)
- d. 4 Feet
- e. 2 Fork Pieces
- f. 1 Fork Spacer
- g. 2 Long Desk Frame Rails
- h. 3 Desk Frame Stiles
- i. 1 Desk Ledge
- j. 4 Desk Slats

Hardware and Knobs:

- k. 2 Wooden Knobs (drilled through)
- l. 2 Wooden Knobs (w/T Nuts)
- 1 Carriage bolt, 1/4" x 4 1/2"
- 1 Carriage bolt, 1/4" x 5"
- 2 Washers
- 6 Drywall screws, #6 X 1"
- 1 Leather scrap, 1" square
- 4 Wood plugs, 3/4"
- 4 Wood plugs, 3/8"
- 4 Pair, steel connectors, 4"
- 24 Bracket screws, #6 X 1"

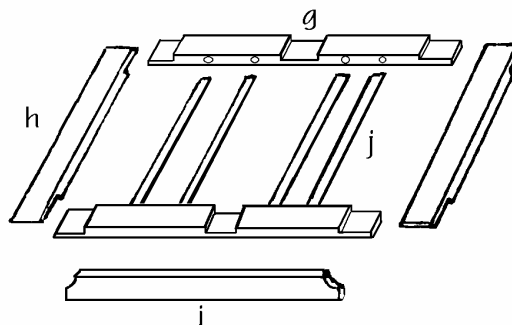
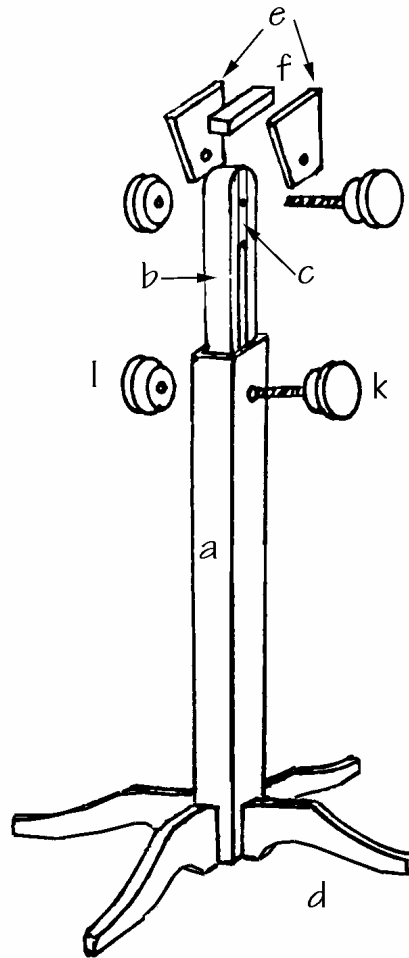

____ **1.** Please check through the parts of this kit, using the drawing above to identify them. If you find any parts missing or unsatisfactory, don't hesitate to notify us so we can correct the problem right away.

____ **2.** Begin by preparing the **COLUMN** and **FEET**. You will want to round over the sharp edges of these parts before assembling them. We use a router with a 1/4" rounding over bit, but you can achieve good results with coarse sandpaper (80-100 grit) wrapped around a scrap of wood.

Round over the upper edges of all four **FEET**.



Round over the long side edges of the **COLUMN**.

Round over the top edges of the **COLUMN**, being careful to make sure your router bit will not "fall" into the opening! If the roller guide does not make contact with solid wood here, then switch to sandpaper for this portion of the task.

NOTE: This may seem like an unnecessary bit of hand work, but your **PODIUM** will look much more professional if you take the time to accomplish the small jobs like sanding and rounding over.

____ **3.** Find the 4" **STEEL CONNECTORS** in your hardware pack. Notice that they are paired up and tapered so that *the smaller half slides firmly into the larger half*.

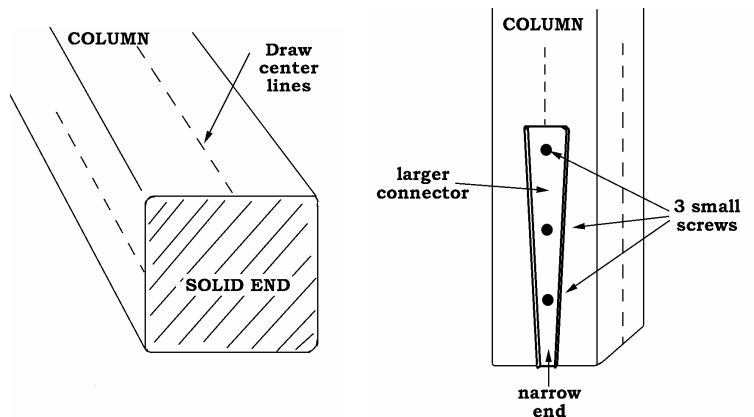

Take care to mount the **CONNECTORS** exactly as shown:

- a) Draw a center line on each face of the **COLUMN**, near the bottom (solid) end.
- b) Use the small 3/4" screws to fasten the larger half of each **CONNECTOR** pair to the **COLUMN**, on your centerlines, so that *the narrow end is flush with the bottom of the COLUMN*.

Use the remaining small screws to fasten the smaller half of each **CONNECTOR** to each **FOOT** (carefully centered in the slot provided), so *the narrow end is flush with the bottom of the FOOT*.

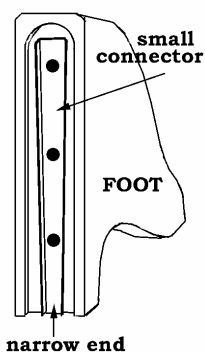

Now you can install and remove the **FEET** to the **COLUMN** at will, using a mallet (or a hammer with a wood block for padding). You may appreciate the removable feet when it comes to transporting the music stand -- it will take up less space with two

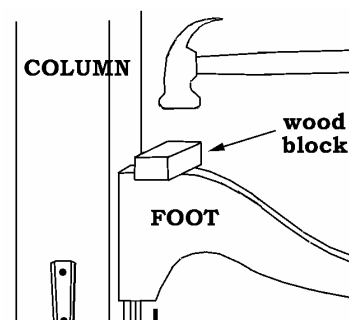

feet removed.

___ **4.** Glue and clamp the **SLIDE** pieces together, as shown, lining up all the parts flush at the ends and edges.

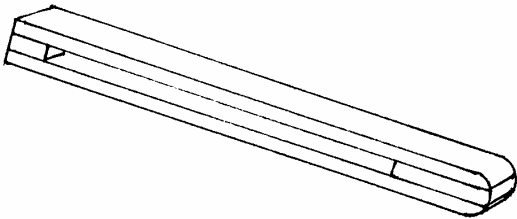

___ **5.** Notice that one **SPACER** is longer than the other in the **SLIDE** assembly. We like to round over that end quite dramatically so it will allow the **DESK** to tilt on its **FORK**.

CAUTION: BE SURE TO ROUND IT IN THE SAME DIRECTION AS SHOWN!

___ **6.** Use medium (150 grit) sandpaper to knock the sharpness off the edges of the **SLIDE** assembly. Test fit it into the **COLUMN** to make sure it slides easily. If not, sand some more (especially the corners).

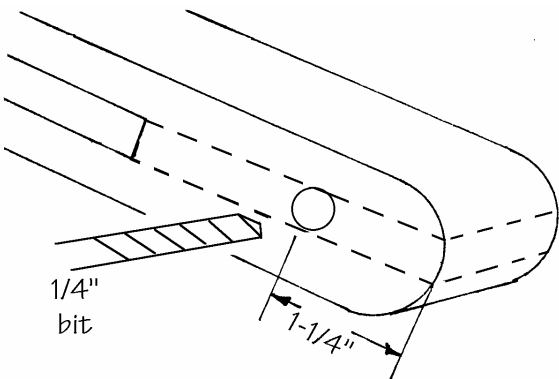

___ **7.** Carefully drill a 1/4" hole in the **SLIDE** assembly, 1-1/4" from the rounded end. If you haven't a drill press available, ask a friend to help you hold the drill vertically for this step. Four eyes are better than two....

CAUTION: BE SURE TO DRILL THE HOLE IN THE SAME DIRECTION AS SHOWN!

___ **8.** Find the three parts for the **FORK** and one **CARRIAGE BOLT** for the next step. Assemble these parts dry (without glue) first, as shown, using the bolt to keep the holes aligned. Try clamping the **FORK** pieces together to make sure the **SLIDE** will rotate freely in the **FORK**.

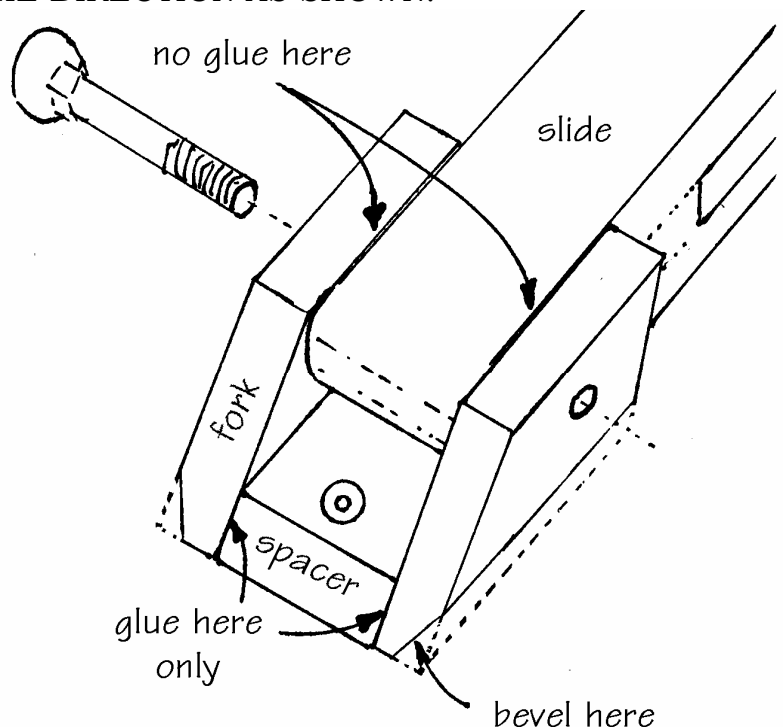

When satisfied with the way the parts fit, put glue on the **FORK SPACER** only, and slip it back into place. Clamp the parts together, making sure **NOT TO PUT GLUE ON THE SLIDE**.

___ **9.** When the **FORK** is dry, sand the outer edges to round over and soften the feel. I also like to bevel the two lower edges where the **FORK** will be glued to the **CENTER STILE**, so the glue surfaces will be about the same width.

___ **10.** Sand the four **DESK SLATS** until the ends will fit into the slots cut in the upper and lower **DESK FRAME RAILS**. Make a dry run to test the fit of all the **DESK** parts together, as shown. Don't worry, there is no way to assemble these parts incorrectly -- they will only fit one way. Try to get a tight fit in each corner.

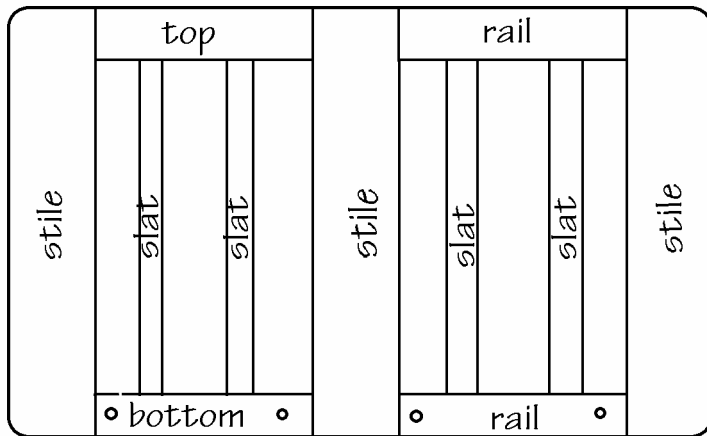

When you get all the parts to fit well, clamp the four corners (dry) and lift off the center **STILE** only. Put glue on the ends of this **STILE** and clamp it back in place. Then remove the other **STILES**, one at a time, put glue on them, and clamp them back in place. No need for glue on the **SLATS** -- they'll stay put without glue.

___ **11.** When the **DESK** is dry, I like to round over the sharp edges all around the outside. A hand-held orbital (palm) sander works quite well for this, beginning with a coarse (80-100 grit) sandpaper and ending with a medium (150 grit). Make sure the edges all feel smooth to the touch, as this will be the part that is handled the most.

___ **12.** The one remaining piece is the **DESK LEDGE** for holding the music. I like to round over one corner at each end quite dramatically before installing this part to the **DESK**. Do not round over the edge that will be glued to the **DESK**, however.

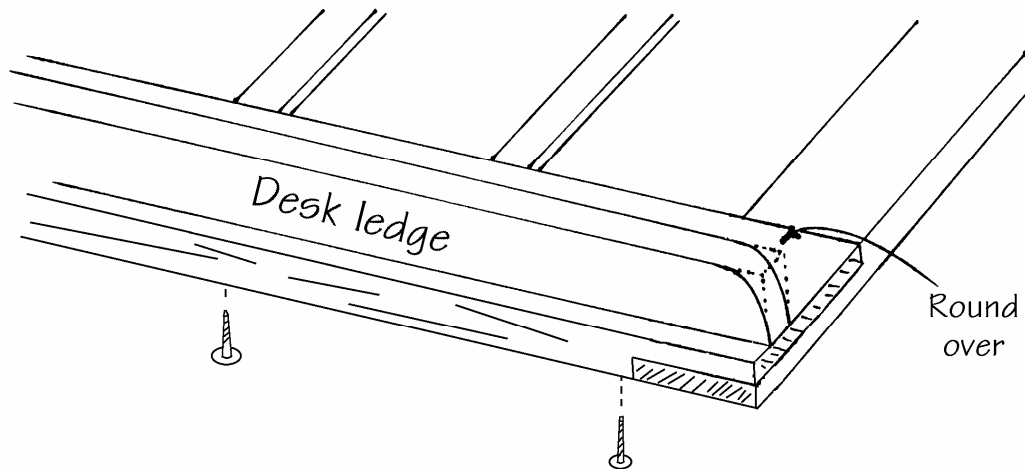

Install the **LEDGE** to the front of the lower **DESK RAIL** with glue and four of the screws provided (you may need to drill 3/32" pilot holes to make sure the screws turn in easily). Again, you cannot fasten this part in the wrong place -- it will only fit on one side of the **DESK** when you put the screws in from the side with countersunk holes. The only challenge here is to make sure the **LEDGE** is centered and level along the **RAIL**. I recommend holding it in place with clamps while drilling the pilot holes. Then the screws will draw the parts together to the same position after applying glue.

____ **13.** Cover over these screw holes with the four small **WOOD PLUGS** provided. Put a drop of glue around the edge of each hole and tap the plugs in with a hammer. When dry, sand the excess **PLUG** material down flush with the surrounding wood surface. Be sure to sand enough to remove any traces of glue.

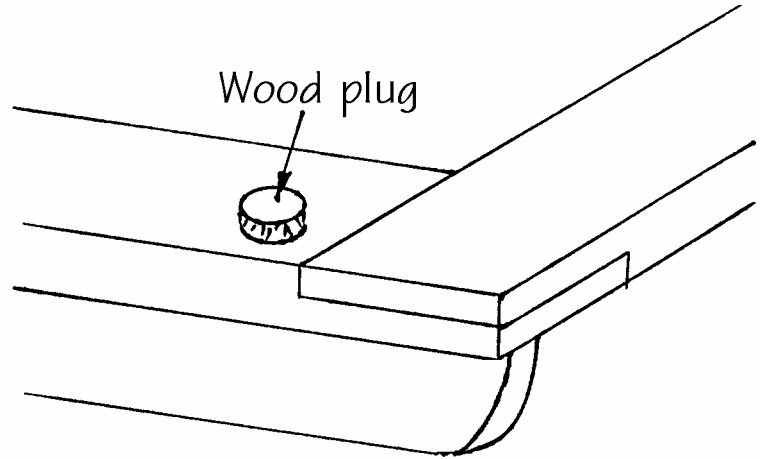

____ **14.** Now you can fasten the **FORK** to the back of the **DESK**. It should be glued and screwed to the center **STILE**, 2-1/2" from the bottom of the **LOWER RAIL**.

There is no top or bottom to the **FORK**, so just line it up carefully on the **STILE** so the **DESK** will not be crooked on the stand.

CAUTION: BE SURE TO FASTEN THIS PART TO THE BACK OF THE DESK, ON THE OPPOSITE SIDE FROM THE MUSIC LEDGE.

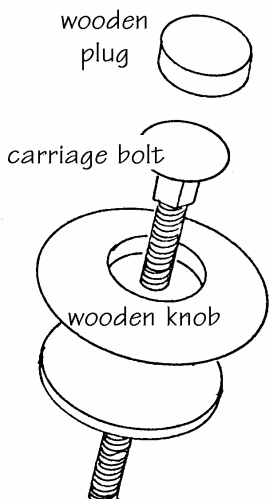
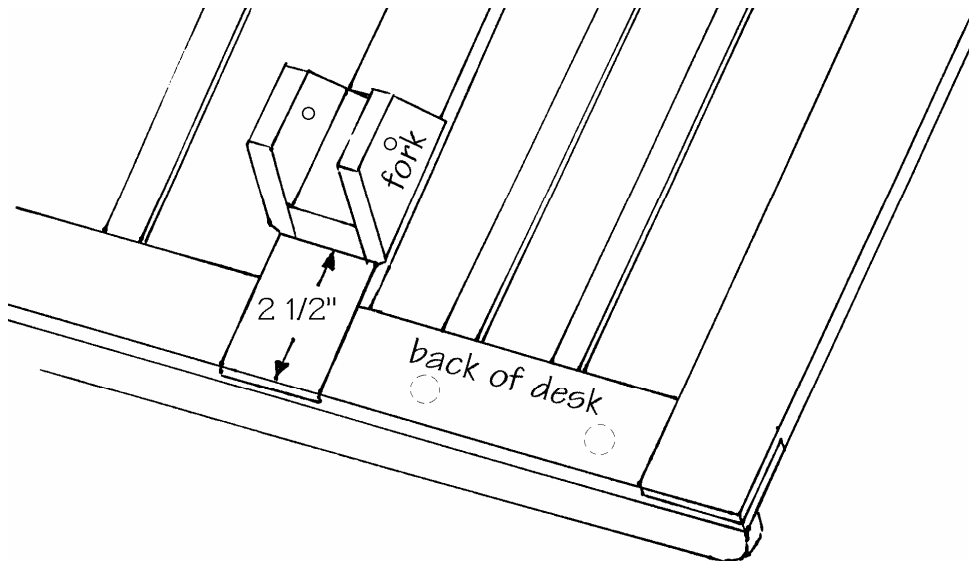

____ **15.** Two of the **WOODEN KNOBS** in your kit have **T-NUTS** already installed in them, and the other two are drilled for **CARRIAGE BOLTS**. You need to tap the two **CARRIAGE BOLTS** into these latter **KNOBS** until the heads are driven all the way down to the flat surface of the countersunk holes. Then you can glue the 3/4" **WOOD PLUGS** into the tops of all four **WOODEN KNOBS**.

When the glue is dry sand off the excess **PLUG** material and round off the top of the **WOODEN KNOBS**. Make sure there is no glue residue left around these **PLUGS**.

____ **16.** Test fit the entire **PODIUM** together, using washers only on the **KNOBS** with bolts to make them easy to turn without scratching the finish.

The other **KNOBS** (without bolts) may be glued in place permanently so you need not hold onto them when tightening the **SLIDE** or **FORK**. Be sure to use the bolted **KNOBS** as clamps to hold the threaded **KNOBS** in place when gluing them. That way you know they will be held in the correct position.

HINT: If you are right-handed, glue the permanent **KNOBS** to the left side (as you face the front of the **MUSIC DESK**), and vice versa.

CAUTION: DO NOT PUT GLUE ON THE KNOBS WITH BOLTS, OR YOU WILL BE UNABLE TO TAKE APART THE PODIUM AGAIN.

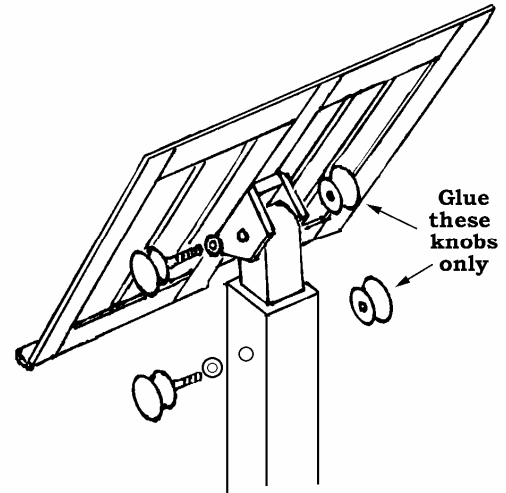

____ **17.** Give the entire project another careful sanding with fine (180-220 grit) sandpaper. Check carefully for glue spots. They are difficult to see now, but they will **GREATLY** detract from the appearance of this piece of furniture after the finish is applied. **ALL VISIBLE GLUE MUST BE SANDED/CHIPPED/SCRAPED AWAY!**

____ **18.** Apply the finish of your choice to the entire **PODIUM**. Don't forget to finish the **WOODEN KNOBS** too. Here are a few suggestions:

STAIN -- STAINS are coloring agents and should only be used if you dislike the natural color of the wood. We usually do not apply stains to our projects, especially when they are made with naturally beautiful hardwoods such as cherry or walnut. These woods look very nice with just a clear finish. But, if you want to color the wood differently, your staining should be accomplished before applying a surface finish such as oil, varnish, or lacquer.

OIL -- An oil finish will give your wood a low luster appearance, bringing out the natural color of the grain, but it tends to soak into the wood and appear dry and "thirsty" after awhile. The principal advantage of an oil finish is that it can be applied and wiped dry immediately, so you can use your stand right away. The disadvantage of oil is that it usually does not give much surface protection or sheen, although there are some brands that include waxes and/or varnishes to give more surface build-up and luster.

VARNISH -- Any regular varnish will work fine on this project, but we recommend our wipe-on gel urethane called MUSICMAKER'S INSTRUMENT FINISH. Our complete finishing kit includes detailed instructions, sandpaper sheets, and a half pint can of satin gel urethane varnish. The advantage of this finish is its simple application, durability, and deep, soft luster.

LACQUER -- Many professional instrument makers use lacquer for their finish. The most readily available lacquer is called Deft Clear Wood Finish. It is best to purchase a can of liquid to brush on as a sealer coat first, and then use an aerosol can of the same product to spray on the final coats. The advantage of this finish is its quick drying time, but the disadvantage is the strong odor of the toxic lacquer fumes.

19. One final detail of assembly is the **LEATHER SCRAP**. This is an optional detail that may not be needed, depending on how slippery your finish coat is. We usually need to put it into the **FORK** as a spacer to help grip the **DESK** more firmly.

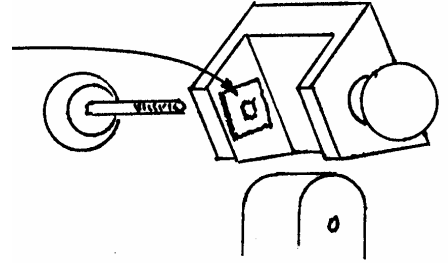

Use a sharp chisel or knife to cut a rough hole in the middle of the **LEATHER** so you can poke the bolt through it. Put the bolt through one side of the **FORK**, just far enough to poke through and hold the **LEATHER** as you position the **FORK** over the top of the **SLIDE** assembly. Finish pushing the bolt through and screw it into the **KNOB** on the other side.

CONGRATULATIONS! You have completed **THE PODIUM** kit. We hope you enjoyed the project and that it will give you many years of good service.

MUSICMAKER'S KITS, INC

P.O. Box 2117

Stillwater, MN 55082-3117

651 439 9120

www.harpkit.com