

Bowed Psaltery Kit



**Musicmaker's Kits
P.O. Box 2117
Stillwater MN 55082
(651) 439-9120
www.harpkit.com**

BOWED PSALTERY KIT

Parts list:

- 2 long side rails
- 2 short side rails
- 1 pin block
- 1 front (soundboard)
- 1 back
- 1 bridge (6-3/4" long)
- 1 mounting pad
- 1 bow

Hardware list:

- 1 tuning wrench
 - 32 tuning pins
 - 32 scuffed hitch pins
 - 1 set of 32 deluxe strings
 - 3" black delrin (1/8" dia)
 - 6-3/4" brass rod (3/32" dia)
 - 1 T-Nut, 1/4" X 20 (to fit mounting pad)
 - 1 length bow hair
 - 1 block rosin
 - 2 drill bits (3/16", 1/8")
 - Medium Donut for optional rosette
-
- 1 set of instructions
 - 1 tuning chart on transparency

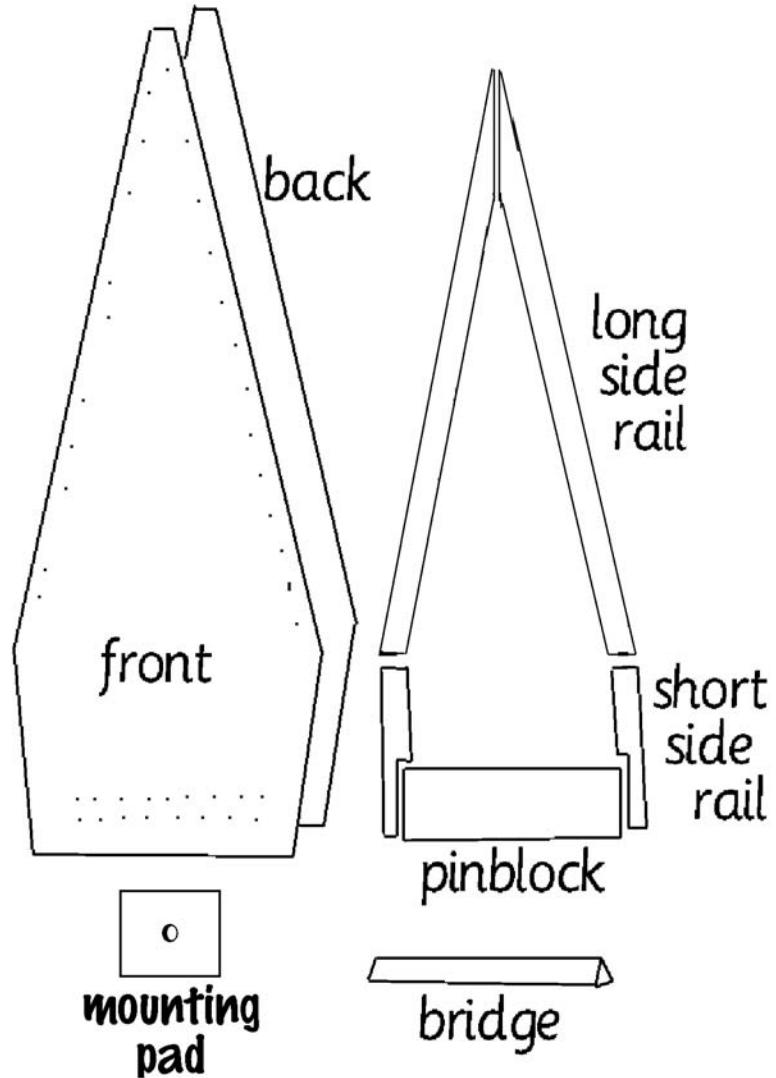

If you have any questions about the assembly of your kit - please visit our online Builder's Forum www.harpskit.com/forum

NOTE ABOUT GLUE

Use good woodworking glue (such as Elmer's Carpenter's Wood Glue) for assembling this kit. Be sure to apply enough glue to cause some to squeeze out of the joints when clamped.

ASSEMBLING THE FRAME

1. Please check over your psaltery kit to make sure everything is present and accounted for. If we goofed in packing your order, call us right away so we can rectify the situation without causing you undue delay.

Please note that we have taped the LONG and SHORT SIDE RAILS together in matched sets, so that when you glue them together, the grain pattern will follow nicely across the joint.

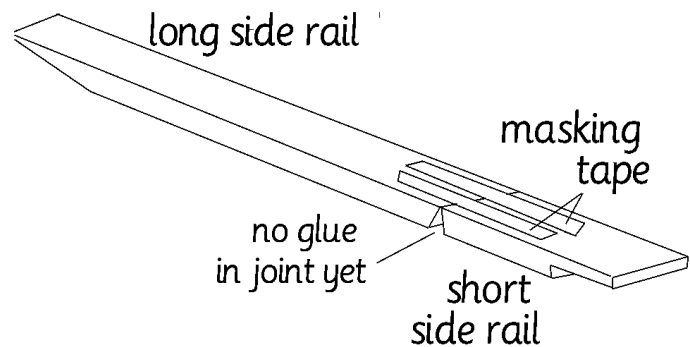

_____2. Be sure to work on a flat surface so the psaltery frame is not twisted. Protect your work surface from glue by covering it with wax paper or plastic.

It may sound too simple, but we assemble this entire frame together in one step using masking tape to hold every joint together until dry. Here is the sequence:

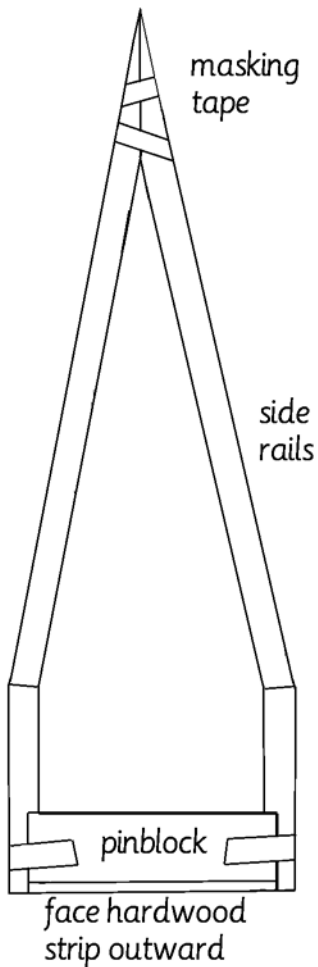

a) Lay the LONG and SHORT SIDE RAILS down flat on your table with the outside facing up, so the points of the V-joint meet each other and the wood grain matches across the joints. Use masking tape to hold these parts together as shown.

b) Test-fit the entire frame together without glue to make sure the parts fit together well. HINT: Face the PINBLOCK so that the thin hardwood surface faces out to match the SIDE RAILS.

c) When satisfied with the fit, get a damp rag for quick clean-up before proceeding with glue.

d) With both SIDE RAIL assemblies held together at the V-joint, turn these SIDE RAILS upside down and squirt glue in three places: the wide ledge at the bottom, the small V-groove of the joint, and the tapered inside face of the point

Work quickly to assemble the entire frame, as shown.

Use more masking tape to hold all the joints together. Be sure to flip the frame over and apply masking tape to the other side too. The goal is to draw all seams tightly together so glue squeezes out of each joint. Check each joint carefully to make

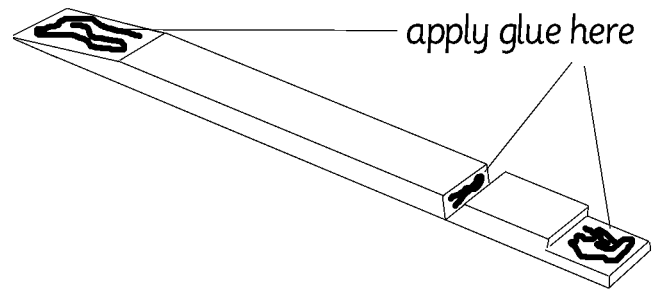

sure the parts are properly lined up and held tightly together. Use your damp rag to clean up excess glue before it dries. Leave the whole assembly for at least 30 minutes until the glue sets.

POINT OF INTEREST

You may wonder why we do not provide a solid block of wood for the PINBLOCK. This material is made from many layers of hard maple cross-laminated for extra strength. It is the same type of material used for piano pin blocks. The cross-laminated layers hold the tuning pins from all directions for excellent tuning stability. We cover one edge of the block with cherry or walnut to hide the maple laminations inside the box.

_____3. When the frame is dry, remove the masking tape and check over all the surfaces and joints to make sure they are clean and smooth. If necessary, use a sharp knife or chisel to smooth out the joints and remove hardened glue bumps.

_____4. Find the BACK panel for your instrument. It is the laminated sheet of thin wood, cut slightly larger than the frame of the psaltery.

Select the face you wish to show outward on the instrument and place that face down on your work surface. Position the psaltery frame on the BACK to check the fit. There should be about 1/8" of excess BACK material showing around the entire frame.

When satisfied with the fit, squirt a healthy bead of glue around the edges of the entire frame where it makes contact with the BACK, reposition the frame on the BACK, and hold the assembly together with heavy weights or several clamps.

You should see some glue squeezing out around the entire circumference of the frame.

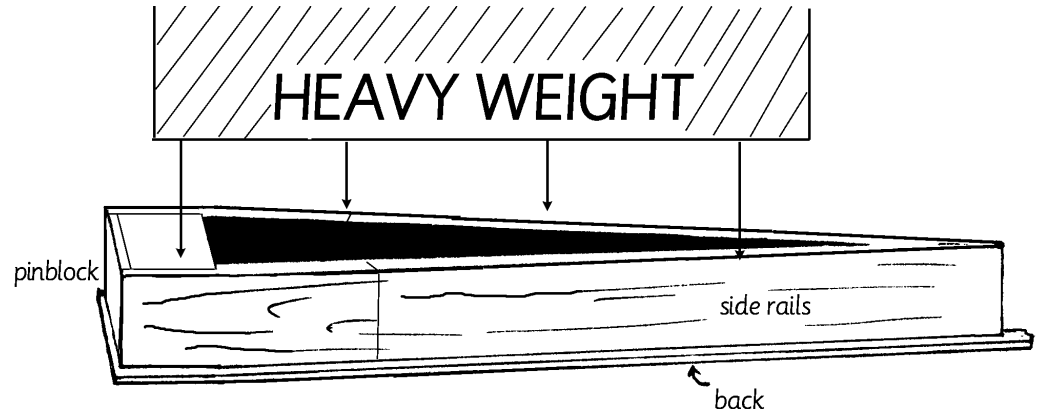

5. When dry, trim the excess lip of wood from the BACK so all edges are flush and smooth. Coarse sandpaper or a wood rasp should accomplish this, unless you happen to have a router with a flush-cutting bit for quick results.

6. (Optional) You may add the mounting pad for enabling you to attach the instrument to a standard camera tripod. The hole in the pad should be centered 7" from the inside of the PINBLOCK, as shown. This will be the balance point of the instrument once it is finished and strung. Clamp this pad firmly in place with glue until dry.

7. (Optional) You will need to drill the hole through the back of the instrument the same size as in the mounting pad (5/16") so you can install the T-nut. Drill slowly so you avoid tearing out the wood in the thin plywood back panel.

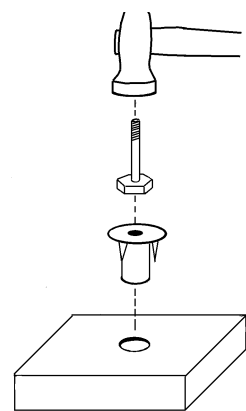

8. (Optional) Insert the T-nut into the mounting pad from the inside of the instrument. Set the instrument on a solid surface and use a hammer with a large bolt as a "driver" to seat the T-nut fully into the pad. The end of the T-nut should come close to showing on the back of the instrument. Then your tripod screw will be able to reach the threads of the T-nut.

SCRATCH-BUILDERS: The mounting pad is made of solid hardwood measuring about 2" square by 1/2" thick. Drill a 5/16" diameter hole through the middle for the T-nut.

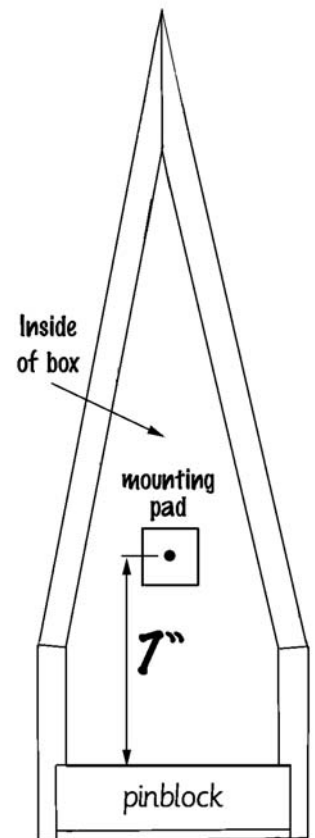

PREPARING THE FRONT (SOUNDBOARD)

9. Please note that the FRONT (SOUNDBOARD) of your psaltery has been punch-marked to show the locations of all the holes for tuning pins, scuffed pins, and position markers. This face must show outward on your instrument.

NOTE FOR LEFT-HAND CONFIGURATION

If you would like to make a left-handed psaltery, use a small drill (1/16" bit) to bore through the soundboard at each punch-mark so you can see all the positions clearly on the other side of the FRONT. Take care to count all the positions. There should be 32 marks at the squared end, 32 marks in line along the two sides, and 6 extra marks on one side for position markers.

_____10. Now is the time to cut a sound hole in the FRONT of the instrument. We purposely leave this job for you to customize/decorate as you wish. You will find a pencil mark indicating what we suggest as the centerpoint of your soundhole pattern.

Some people use a scroll saw to cut a fancy shape in the wood, and others simply make a round or oval hole. Your cut-out should not be larger than 2-1/2" across. If it gets much larger than that, it may look awkward and might reduce the strength of the FRONT panel.

If your selection of tools is limited, or you are in a hurry, you may accomplish fine results by simply drilling a number of smaller holes (say, 3/8" diameter) in a cluster pattern. Use a ruler to space these holes evenly to form an attractive pattern.

Another easy option is to cut a 2-3/8" diameter round hole and decorate it by inlaying one of our medium size laser-cut wood rosettes. Use a hole saw (available at hardware stores) for cutting the round hole. Our medium size (2-3/8") rosette will fit the hole, but you'll need to support the rosette with the medium "donut" ring included in your kit. The ring should be glued to the inside surface of the soundboard so it creates a ledge to support the edge of the rosette all the way around.

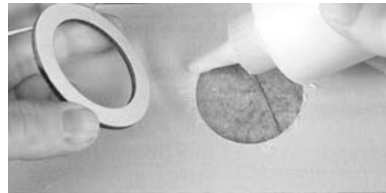

Inside face of soundboard

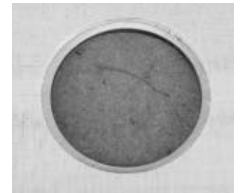

Outside face of soundboard

If you did not order a rosette with your kit, but you want to install one, you may order it now and proceed with assembly. The rosette will be glued in place just prior to installing the strings.

_____11. Now is a good time to sign and date the inside of your instrument where it can be seen through the sound hole (below the mounting pad).

_____12. When the FRONT is ready, you can glue it to the frame in the same way that you glued the BACK, upside down on a flat work surface.

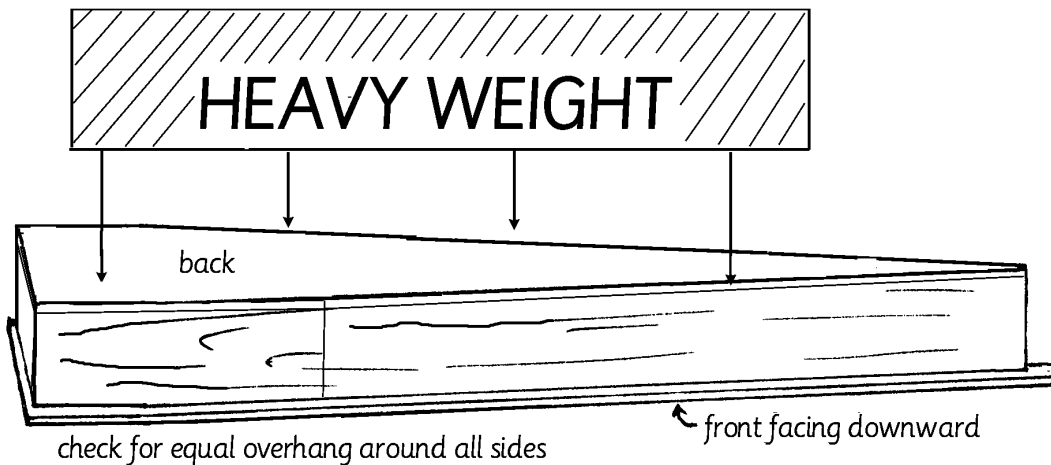

BE CAREFUL to make sure the punch-marks will show on the outside of the box! Those are your drilling guides.

CAUTION: Be sure to center the frame carefully on the FRONT. This is important to ensure that the holes will be properly centered on the SIDE RAILS later in the project.

_____13. Again, trim away the excess wood from the FRONT, so the edges of the instrument are flush and smooth.

_____14. The holes for the tuning pins and scuffed pins should be located according to the punch-marks on the FRONT. If, for some reason, your FRONT panel slid to one side while being glued in place, you may need to adjust the positions of these punch-marks accordingly. The scuffed pins should be centered along a line that is 5/16" from each edge of the SIDE RAILS. The 6 position markers should be centered on a line that is 3/16" from the edge of the one SIDE RAIL. It is unlikely that the tuning pin holes would have to be adjusted over the PINBLOCK, as there is quite a wide area of acceptable positions for them.

_____15. Use a drill press for all drilling. Here is our recommended drilling sequence:

Drill the 6 position markers first, so you do not confuse them with the scuffed-pin holes. Use the 1/8" drill bit (smaller size) provided in the kit, and drill these six holes just 1/4" deep.

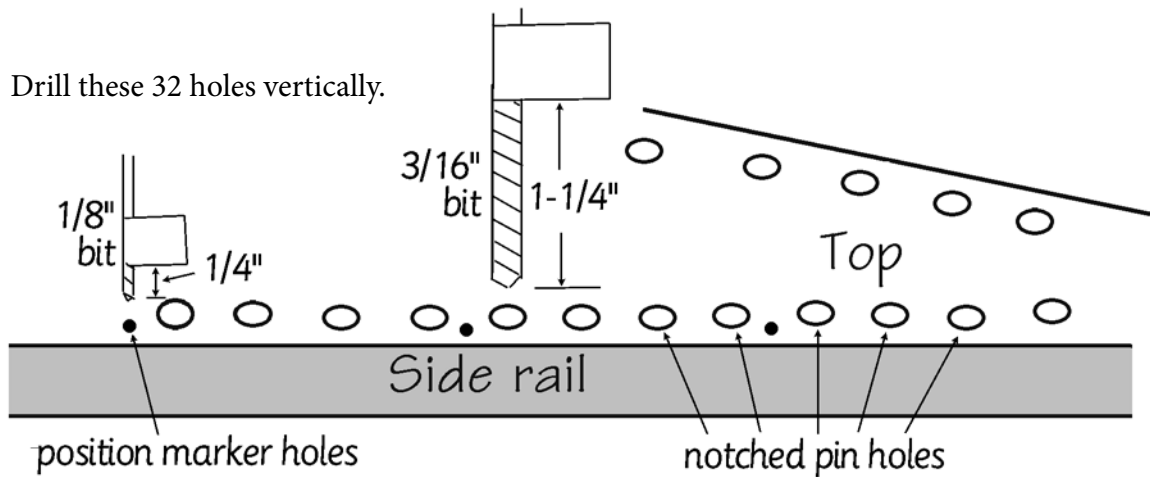

Now use the 3/16" bit provided in the kit for drilling all 32 holes for scuffed pins along the SIDE RAILS. Drill each hole to a depth of 1-1/4". Wrap masking tape around the bit to mark the proper depth. These holes should be straight (vertical) and even.

Tilt the table of your drill press about 10-15 degrees, or prop up the square end of the instrument on a scrap block of wood to achieve a similar angle for the tuning pin holes. Drill all 32 holes for tuning pins with the 3/16" bit to 1-1/4" depth.

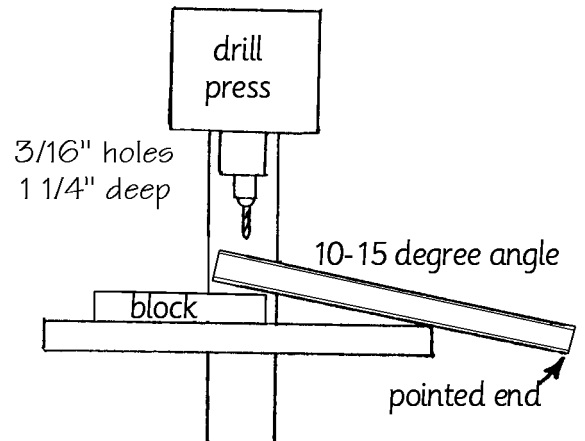

_____16. Round over all points, corners, and edges of the instrument, as shown. You may use coarse (80 grit) sandpaper on a block of wood for this purpose, or make use of your router with a 1/8" radius round-over bit for quick work.

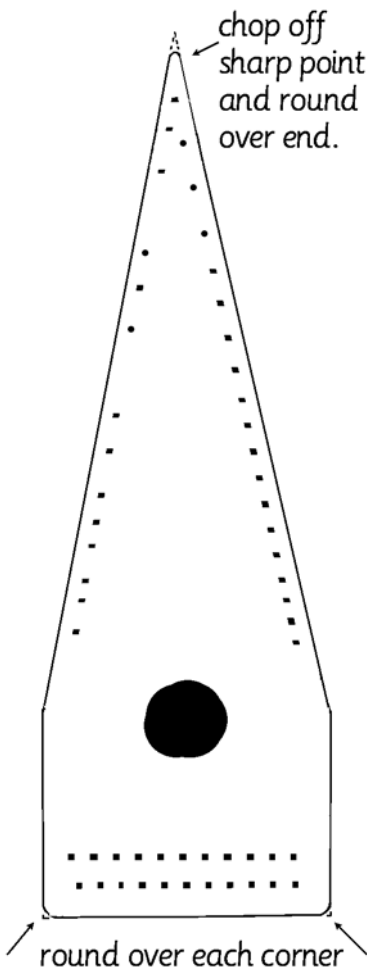

_____17. Now you are ready for final sanding! We use a small orbital "palm" sander at this point, but you can accomplish the same results with a little "elbow grease" by wrapping medium (180 grit) sandpaper around a scrap of wood. Sand the top surface with the grain until it feels smooth and soft. Round over the edges of the entire instrument so it feels good to hold in your hands - no sharp corners. Sand the sides and back with the grain to your satisfaction.

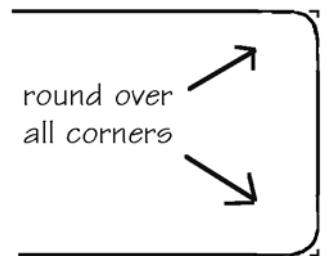

NOTE: If you are interested in further decoration with a wood burner or with hand painting, this might be the best time to do so. Mark the position of the bridge on the top (2-1/4" from square end), and then create your patterns for decoration. Avoid painting where the BRIDGE is to be glued.

_____18. Sand the BRIDGE to make it smooth. Be careful not to sand off the groove that has been routed on the top. Then glue it to the position shown here on the FRONT.

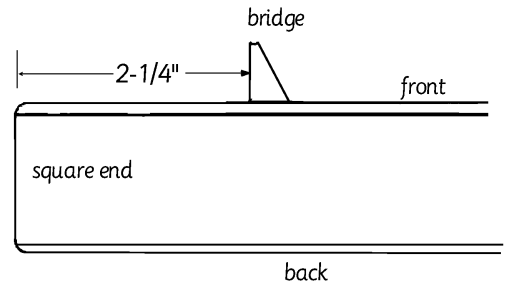

_____19. Find the 3" piece of black delrin (plastic) rod. Tap it into the first small hole for position markers, and then cut it off close to the surface of the top. Tap the remaining piece into the next small hole and cut it off, and so on for all six small holes along one side of the instrument. Then use a very sharp knife or razor blade to trim each black inlay marker flush with the top of the instrument.

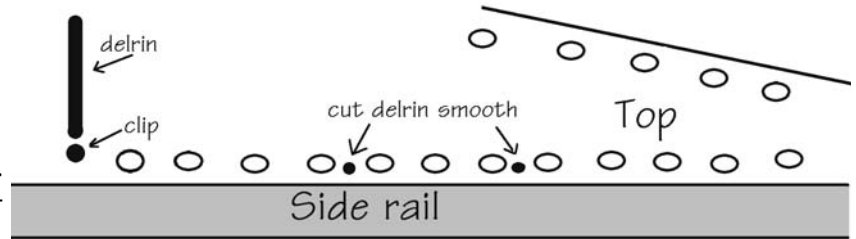

_____20. Finish the instrument as desired. Here are a few guidelines for the various finishing options available on the market:

STAIN -- STAINS are coloring agents and should only be used if you dislike the natural color of the wood. We usually do not apply stains to our projects, especially when they are made with naturally beautiful hardwoods such as cherry or walnut. These woods look very nice with just a clear finish. But, if you want to color the wood differently, your staining should be accomplished before applying a surface finish such as oil, varnish, or lacquer.

OIL -- An oil finish will give your wood a low luster appearance, bringing out the natural color of the grain, but it tends to soak into the wood and appear dry and "thirsty" after awhile. The principal advantage of an oil finish is that it can be applied and wiped dry immediately, so you can proceed to installing hardware (and strings) right away. The disadvantages of oil are that it usually does not give much surface protection or sheen, although there are some brands that include waxes and/or varnishes to give more surface build-up and luster.

VARNISH -- Any regular varnish will work fine on this project, but we recommend our **MUSICMAKER'S INSTRUMENT FINISH**. Our complete finishing kit includes detailed instructions, sandpaper sheets and a 1/2 pint can of wipe-on gel urethane varnish. The advantages of this finish are its simple application, durability, and deep, soft luster. It also works well for protecting decals and painted decorations.

LACQUER -- Many professional instrument makers still use lacquer for their finish. The most readily available lacquer is called Deft Clear Wood Finish. It is best to purchase a can of liquid to brush on as a sealer coat first, and then use an aerosol can of the same product to spray on the final coats. The advantage of this finish is its quick drying time, but the disadvantage is the strong odor of the toxic lacquer fumes. **CAUTION:** Lacquer finish may not work over certain decorations -- it has strong solvents that may cause paint to blister or run.

NOTE: Don't forget to finish the bow and the top of the decorative rosette, if you plan to add one to the sound hole.

INSTALLING HARDWARE

_____21. Locate the bag of scuffed pins. The only difference between these and the tuning pins is the sanded scuff-marks across the top. You may use a hammer to pound these 32 pins part way into the holes along each SIDE RAIL, and then use the tuning wrench to turn them to a uniform depth so they stand about 1/8" taller than the height of the bridge.

If you have access to a drill press, you can press the pins into the wood to the desired depth. Chuck a bolt into the jaws of the drill press, set the depth gauge, and then pull on the handle to push the pins down into the wood. **DO NOT TURN THE DRILL PRESS ON!**

If you happen to drive the pins in too far or not far enough, simply use the tuning wrench to turn them up or down - they are threaded. Lay a straight-edge across the tops of all the pins to see which ones need turning up or down. The instrument will be easier to play if all the scuffed pins are standing the same height.

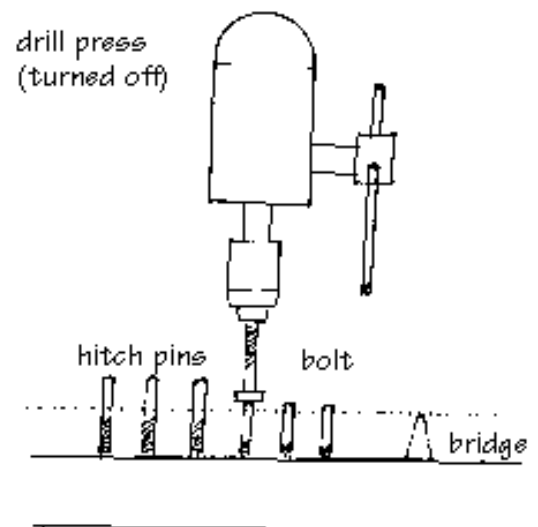

_____22. Use the tuning wrench to turn each scuffed pin until the tiny holes for the strings all aim toward the bridge.

_____23. Pound or press the 32 tuning pins into the holes at the square end of the box so they stand about 1" above the surface of the wood.

_____24. Now that the pounding is over, you may glue the decorative rosette to the sound hole. Use Superglue or Krazy Glue to glue the decoration to your finished surface.

If you glued the rosette on earlier, double-check to make sure it has not become loosened by the jarring action of installing the pins. If the rosette is not firmly glued down, it will likely cause a disturbing buzzing sound when you play the instrument.

_____25. String the instrument as follows:

a) Lay the BRASS ROD on top of the BRIDGE, holding it temporarily in place with some masking tape until the first few strings are installed.

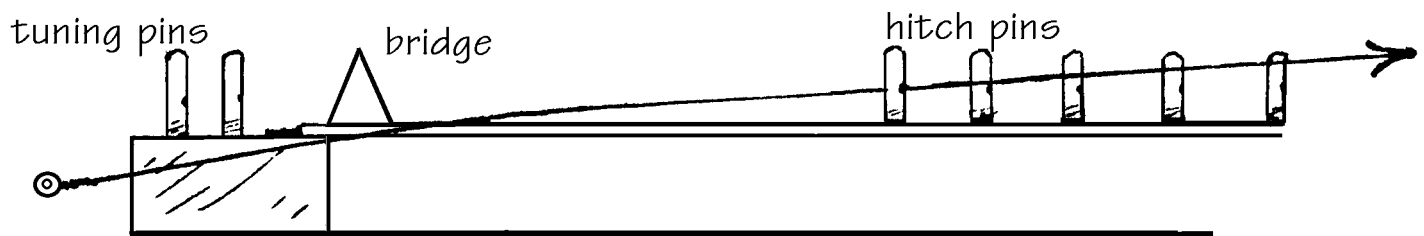

b) Poke the end of one .010" dia. wire through the hole in the first scuffed pin, passing it through the pin in the direction of the point.

c) Pull the string all the way through and draw it up over the top of the scuffed pin, to the top of the bridge, and then across the instrument to the correct tuning pin.

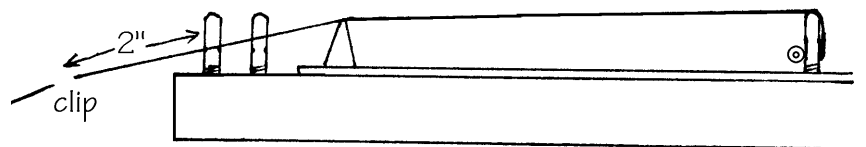

d) Clip off the excess wire so that it measures only about 2 inches beyond the tuning pin.

e) Insert the string into the hole in the tuning pin so that it just pokes through the other side.

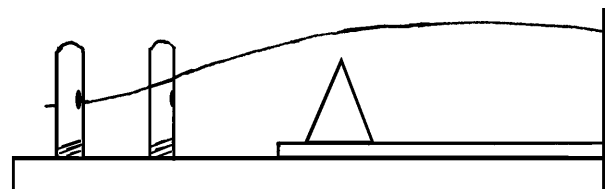

f) Turn the pin clockwise with the tuning wrench to wind the string onto the pin. Try to make the string wind downwards on the pin. Tighten only enough to pull the wire taut across the span.

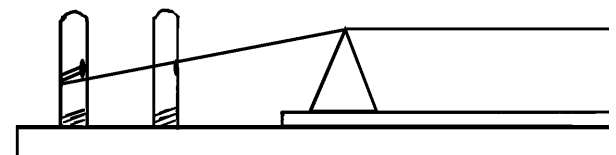

NOTE: You may find it helpful to ask a friend to participate in this part of the project. Sometimes two hands are just not enough! One person can keep the wire from falling off the top of the scuffed pin while the other person turns the tuning pin and guides the wire windings.

g) Attach all the rest of the strings, in order, the same way. Take note of where the string sizes should be changed.

_____26. Tune your psaltery to the notes shown on the tuning chart at the end of these directions. The longest string that runs down the center is the lowest note, "middle C". All other notes go up the scale from there, with naturals along the right side and sharps/flats along the left. You will notice that the black marks identify all the "C" and "F" notes on the scale.

PREPARING THE BOW

_____ 27. Tie a simple overhand knot in one end of the bow hair. Slip the hair through the slot at the pointed end of the bow, as shown:

Hold the bow up in the air so you can comb the bow hair with a regular pocket comb as it hangs down from the tip. You want the hairs to be as straight and smooth as possible.

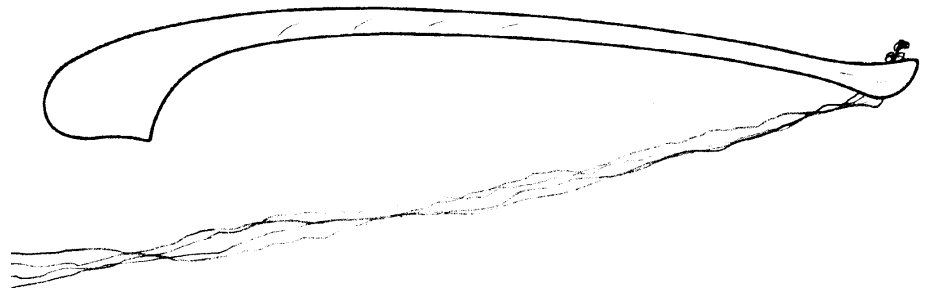

_____ 28. Clamp the bow upside-down in a vise or woodworking clamp to hold it firmly as you install the hair.

_____ 29. Tie the second knot about even with the other end of the bow, as shown. Try to keep the hairs straight and smooth as you tie the knot. Then slide the hair into the slot to test the tension. The bow hair will tighten as the knot is pushed around the curve of the bow. If it isn't tight enough, take it out and re-tie the knot in a different spot. Trial and error will produce the proper tension.

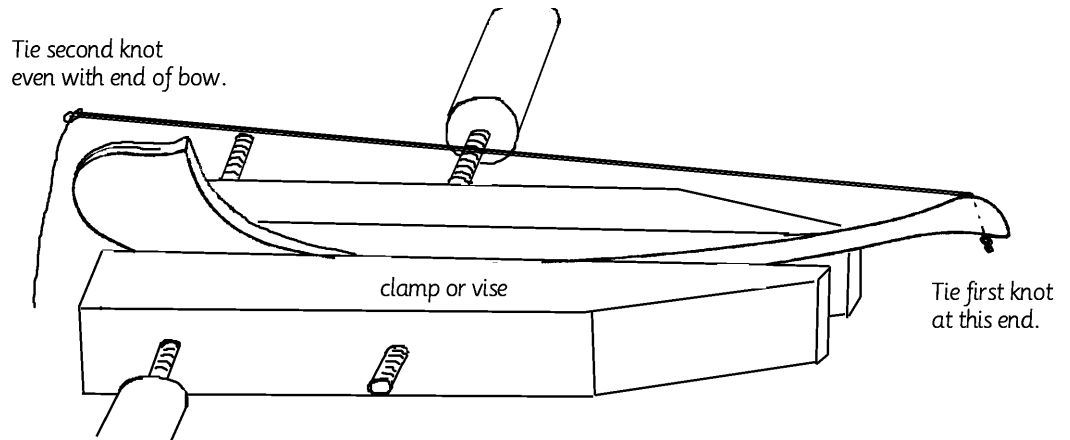

Slide knot around handle of bow until the hair becomes taut.

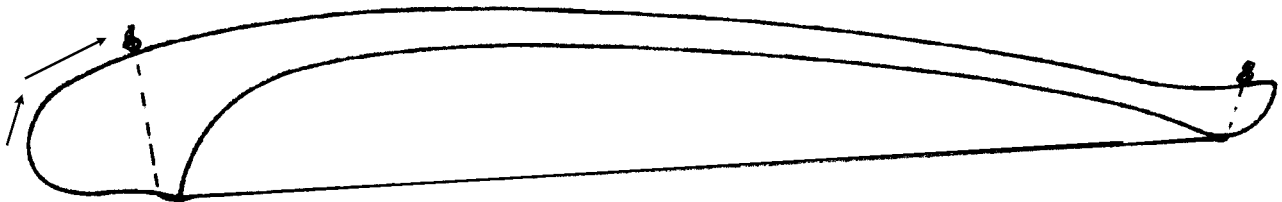

_____ 30. When satisfied with the tension, work some glue into both knots to prevent them from loosening in the future. When the glue is dry, you can clip off the unsightly excess hair at each end, just above the knot.

_____ 31. Chip off a little corner of rosin from the block enclosed in this kit, put the small chip of rosin in a plastic bag and pulverize it into a fine powder. Work that fine dust into the threads of the bow hair along the entire length of the bow, as an initial preparation. Better yet, dissolve this rosin powder in a few drops of alcohol so you can "paint" the sticky solution onto the bow hair for a more thorough initial application. After it dries you can pull the bow forcefully across the remaining block of rosin to add more friction to the bow hair. Without a healthy application of rosin, the bow will not play the strings of your instrument.

_____ 31. Chip off a little corner of rosin from the block enclosed in this kit, put the small chip of rosin in a plastic bag and pulverize it into a fine powder. Work that fine dust into the threads of the bow hair along the entire length of the bow, as an initial preparation. Better yet, dissolve this rosin powder in a few drops of alcohol so you can "paint" the sticky solution onto the bow hair for a more thorough initial application. After it dries you can pull the bow forcefully across the remaining block of rosin to add more friction to the bow hair. Without a healthy application of rosin, the bow will not play the strings of your instrument.

CONGRATULATIONS! Your Bowed Psaltery is now ready to play. We hope you enjoy many years of musical pleasure from your new instrument.

TUNING INSTRUCTIONS

Cut the TUNING CHART transparency along the lines and tape the parts together at the horizontal lines. Then you can slide the tuning chart under the strings to help guide you with tuning the instrument.

The notes along the right-hand side of the instrument are all “natural” notes (like the white keys of the piano), and those along the left side are all sharps/flats (like the black keys of the piano).

Start on the right side with the shortest string, the highest “g” note, two and one-half above middle C. If you have a piano or electric keyboard, you can count out 19 white keys to the right of middle “C” to find this first note.

Pluck that shortest string to see how the pitch relates to the note to which it should be tuned. To adjust the pitch, be careful to place your tuning wrench on the correct tuning pin, and turn the pin SLOWLY as you keep plucking the string to hear the effect of your efforts. Turning the pin clockwise will raise the pitch, and turning it counter-clockwise will lower it.

The shortest strings can be fussy to tune, because the slightest turn of the wrench causes a significant change in the pitch. If you have difficulty arriving at just the right pitch, try tuning the string a bit too high and then pushing on it with your finger. That should lower the pitch somewhat by stretching the wire. A little trial and error should suffice.

Continue tuning down the right side of the instrument, matching the pitches with the white keys of the piano, as shown on the tuning chart. The longest string, which reaches to the very point of the triangle, should be tuned to middle C.

As you move over to the left-hand side of the psaltery, the first string near the middle should be tuned to C#. Work your way up the left side, matching the pitches to the black keys of the piano as you go. The shortest string on the left should match the high F# key, about 2-1/2 octaves above middle “C”.

If this is the first tuning for your instrument, you may find that some of the strings you tightened need to be tuned again already. This happens because the wire strings are still stretching under the tension. To hurry this “settling” process, you might push on the strings with your finger to stretch the wire before tuning the second time. Then the strings should stay in tune quite well.

HOLDING THE INSTRUMENT

If you are standing, hold the psaltery at about chest height on your left fore-arm, with the square end resting against your abdomen. In that position you will be able to comfortably handle the bowing motions with your right hand, playing strings along either side of the instrument. If you are sitting, you may try crossing your legs and resting the instrument on your lap. In such a position you will be able to use two bows, one in each hand, for playing harmonies.

USING THE BOW

Hold the bow with the fingertips of your right hand. Rest the bow hair on one of the psaltery strings (no need to press hard) and draw the full length of the bow across that string, making a long, even note. Push the full length of the bow across the same string in the opposite direction.

Bowing technique may take a little time to develop. Try to keep a light but even pressure on the bow as you stroke the strings, one at a time. Tilt the bow downward on the right side to play the natural notes, and downward on the left to play the sharps and flats along the other side. With a little practice, you’ll be able to move quickly up and down the scale.

If you wish to use music, we recommend any sheet music or songbook that shows the melody in the treble clef. You can play both the alto and soprano ranges on this instrument. Playing by ear is also quite simple, especially in the key of “c”, because the notes on the right side of the psaltery form the “do, re, mi” scale, beginning at either of the “c” strings (marked with a black dot).

BOWED PSALTERY
STRINGING CHART

String	Size	Note	Code
1	.010	G6	BALL-01
2	.010	F6#	BALL-01
3	.010	F6	BALL-01
4	.010	E6	BALL-01
5	.010	D6#	BALL-01
6	.010	D6	BALL-01
7	.010	C6#	BALL-01
8	.010	C6	BALL-01
9	.010	B5	BALL-01
10	.010	A5#	BALL-01
11	.010	A5	BALL-01
12	.010	G5#	BALL-01
13	.010	G5	BALL-01
14	.010	F5#	BALL-01
15	.010	F5	BALL-01
16	.010	E5	BALL-01
17	.010	D5#	BALL-01
18	.010	D5	BALL-01
19	.012	C5#	BALL-03
20	.012	C5	BALL-03
21	.012	B4	BALL-03
22	.012	A4#	BALL-03
23	.012	A4	BALL-03
24	.012	G4#	BALL-03
25	.012	G4	BALL-03
26	.014	F4#	BALL-05
27	.014	F4	BALL-05
28	.014	E4	BALL-05
29	.014	D4#	BALL-05
30	.014	D4	BALL-05
31	.014	C4#	BALL-05
32	.014	C4	BALL-05

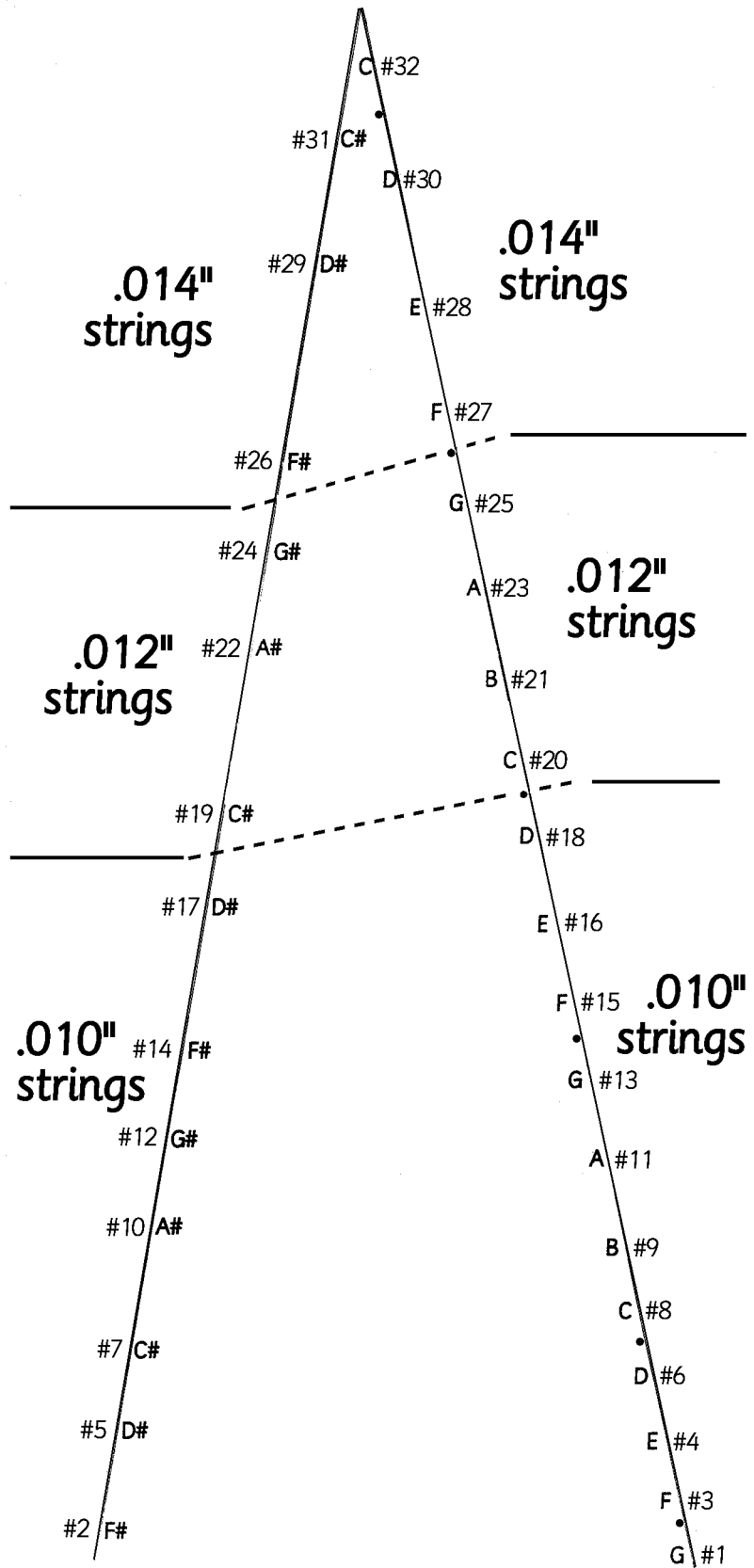

NOTE: If purchasing replacement strings from another source, ask for "ball-end" guitar strings in the diameters shown above. They should be available at most music stores.

ACCESSORIES

Padded carrying Bag
Extra Bow kit
Finished Extra Bow
Cake of Rosin
Spare set of 32 Deluxe Strings
Extra L-Handle Tuning Wrench
Optional T-handle Tuning Wrench
Please consult our website or catalog for current pricing.



Musicmakers

PO Box 2117
Stillwater, MN 55082

651-439-9120

www.harokit.com