

# DAKOTA MANDOLA KIT



**MUSICMAKER'S KITS, INC**  
**PO Box 2117**  
**Stillwater, MN 55082**

**651-439-9120**  
**[harpkit.com](http://harpkit.com)**

# DAKOTA MANDOLA KIT

## WOOD PARTS:

- A - Neck
- B - Fingerboard
- C - Heel Block
- D - Tail Block
- E - Clamping Block
- F - 2 Short Ribs
- G - 4 Corner Blocks
- H - 2 Mid-Ribs
- I - Long Tail Rib
- J - 2 Dowels, 1/4" X 1"
- K - 2 Clamping Wedges
- L - Back
- M - 2 Braces for Back
- N - Front (Soundboard)
- O - 5 Braces for Front
- P - Bridge
- Q - Spacer Block (11")

## HARDWARE:

- 40" Fretwire
- 1 White Side Marker Rod, 5/64"
- 8 Gold Geared Tuners  
w/bushings & 10 screws
- Set of Mandola Strings
- Tailpiece w/3 screws
- White Nut Material
- 3 Wood Screws, 1-5/8"
- 2 Tiny Nails
- Drill Bit, 1/16" for tiny screws
- Drill Bit, 5/64" for Marking Dots
- Drill Bit, 7/64" for wood screws
- Drill Bit, 1/4" for dowels
- Medium Donut Ring
- Assembly Instructions

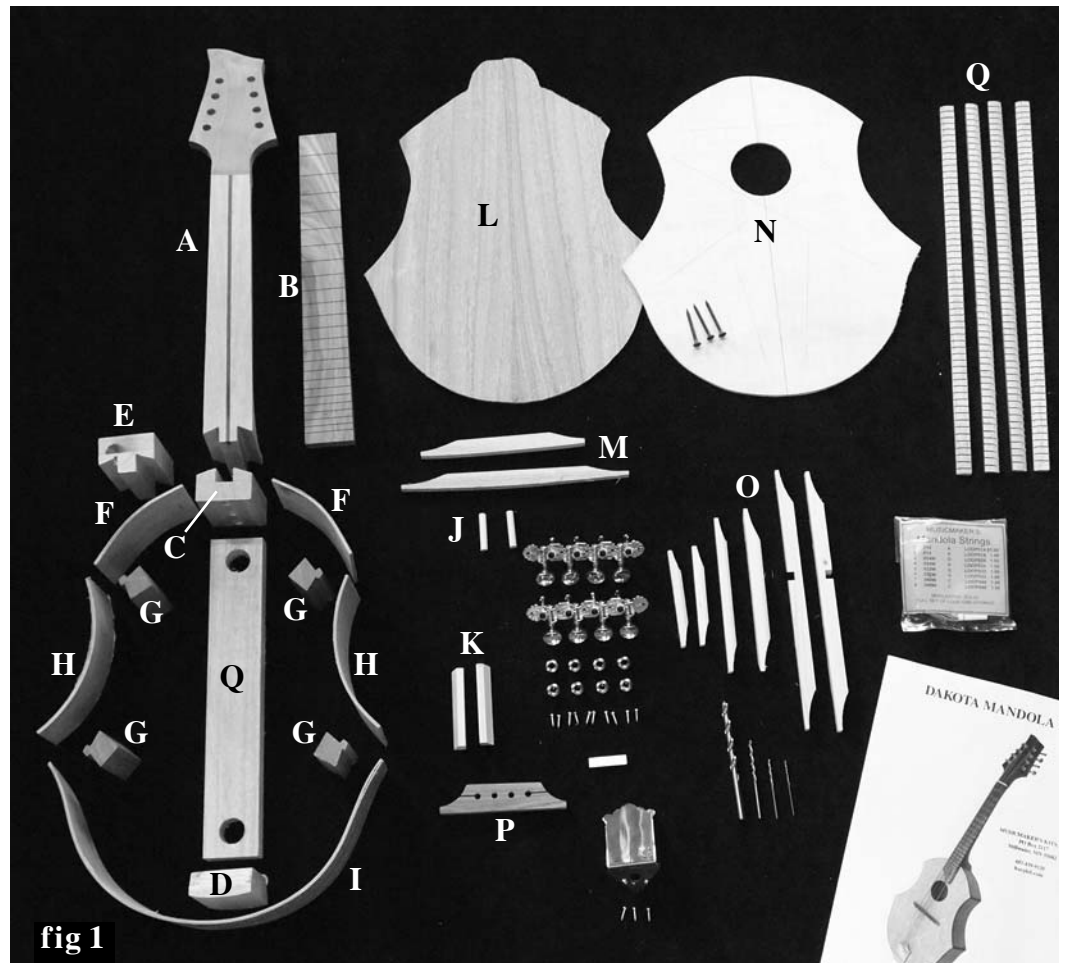

## CUSTOMIZING OPTIONS

If you are an enterprising woodworker who wants to make this project special with some sort of decorations, here are some ideas for you to think about. You may want to order decorative materials now so you have them when you need them.

- 1 Medium Wood Rosette for the Soundhole, with Donut Ring
- 4 strips of Inlay Banding for trimming the Front and Back

## A NOTE ABOUT GLUE

We recommend assembling this kit with standard woodworker's glue (such as Elmer's Carpenters Glue or Titebond Wood Glue). Don't use Hotmelt glue, Superglue, 5-minute Epoxy, or the plain white School Glue for assembling the major wood parts -- they are not strong enough for a high-tension instrument. There is no need to look for any special violin-maker's adhesive. You may, however, see epoxy or superglue recommended in one or two steps for installing non-wood parts.

If you have any questions about the assembly of your kit - please visit our online Builder's Forum

[www.harppkit.com/forum](http://www.harppkit.com/forum)

Every time you use wood glue on this project, it is wise to have a damp rag handy for cleaning up afterwards. It is always best to scrub away any excess glue that squeezes out of the joints before it dries, especially on the outside of the instrument. Keep your hands and workbench as clean as possible too. Glue smudges will show up vividly on the finished instrument.

## ASSEMBLY INSTRUCTIONS

1. CAUTION: PLEASE DO NOT OPEN THE SEALED PLASTIC BAG CONTAINING THE FRONT AND BACK PANELS UNTIL YOU REACH STEP #14. These two parts need to be kept very dry until you glue the braces on them. Check over your kit parts to make sure you have everything (see fig. 1 above). Contact us right away if you are missing parts so we can rectify the problem without causing too much delay for you. We also recommend checking off each step in the directions as you finish it. You might be skipping forward to another part of the assembly while waiting for something to dry, and it helps to keep track of where you left off.

## GLUING THE BODY FRAME

### Tools Required for This Stage

Masking Tape  
Plastic Grocery Bag  
Wood Glue

Small C-clamps  
Spring Clamps  
Damp Rag

Cordless Hand Drill  
Phillips Driver Bit  
7/64" Drill Bit

\_\_\_\_\_2. Begin at the heel where the body will join the neck. Place the heel block and the clamping block together and drill two pilot holes into the clamping block using the 7/64" drill bit provided, as shown in figures 2a and 2b..

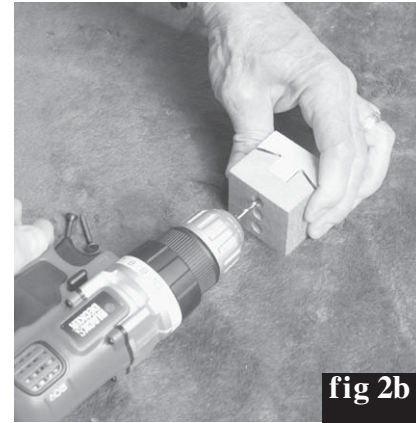
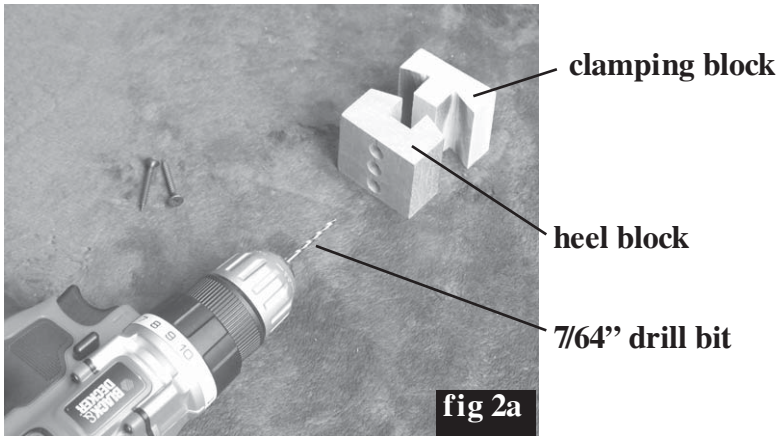

**Hold blocks carefully on a flat surface so they are flush with each other as you drill pilot holes.**

\_\_\_\_\_3. Find the two short ribs and look carefully for pencil markings that show "H" at one end. These are the ends that get glued to the heel block. Orient these pieces carefully: The end of each piece marked "H" will be clamped against the heel block with the pencil marks facing the inside of the body (fig 3a).

Tape the two short ribs to the heel block **WITHOUT GLUE** first, and test the shape against the soundboard (front piece) of the instrument. It is possible to fasten these pieces backwards and have them flared the wrong way!

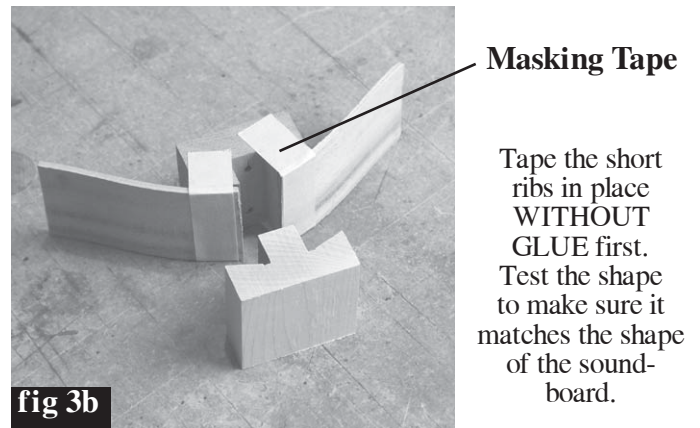
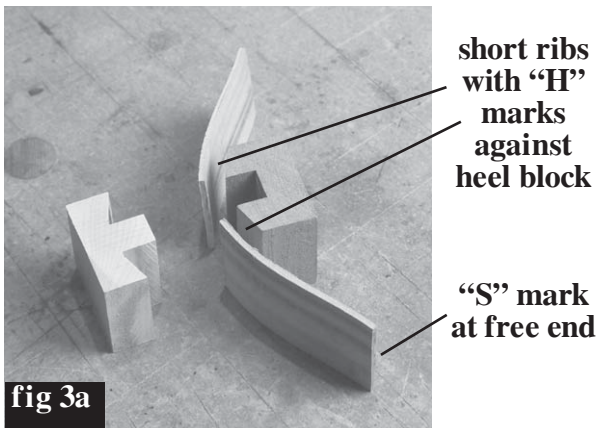

**Masking Tape**  
Tape the short ribs in place **WITHOUT GLUE** first. Test the shape to make sure it matches the shape of the soundboard.

\_\_\_\_\_4. When everything checks out, put glue on the end of each short rib and tape them carefully back against heel block as shown in fig 4a.

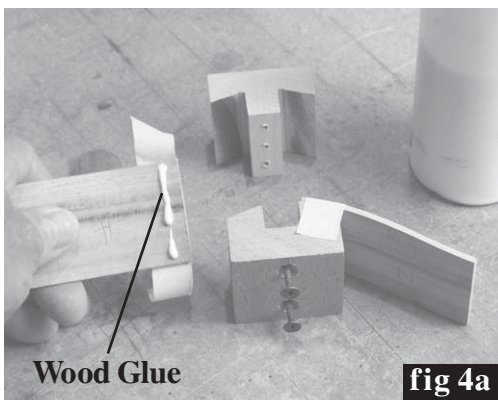

**CAUTION: Don't glue the clamping block to this assembly! Put a thin plastic barrier between the clamping block and the heel block so you can remove the clamping block later.**

Install the screws into the clamping block to draw parts firmly together until the glue dries (fig 4b).

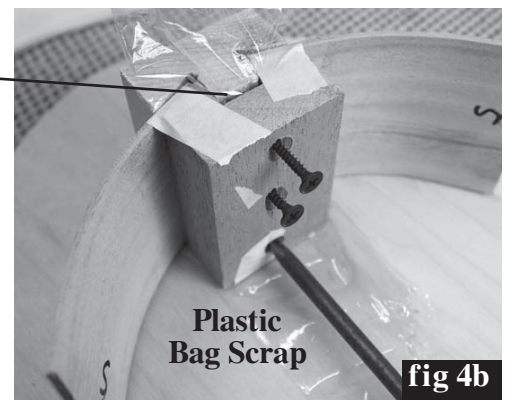



\_\_\_\_ 5. Find the 4 corner blocks. These are all the same, so they are interchangeable. Test-fit a corner to one of the short ribs without glue to make sure your clamp will hold it firmly in place (fig 5a). We have included a couple clamping wedges made of scrap wood in case you need them. When satisfied with the fit, glue and clamp a corner to each short rib, making sure the rib fits all the way into the corner of the ledge (fig 5b).



fig 5a

Allow at least 30 minutes drying time.

After the corners are dry, you can remove the clamps. You can also remove the screws holding the clamping block to the heel block.



fig 5b

tight fit

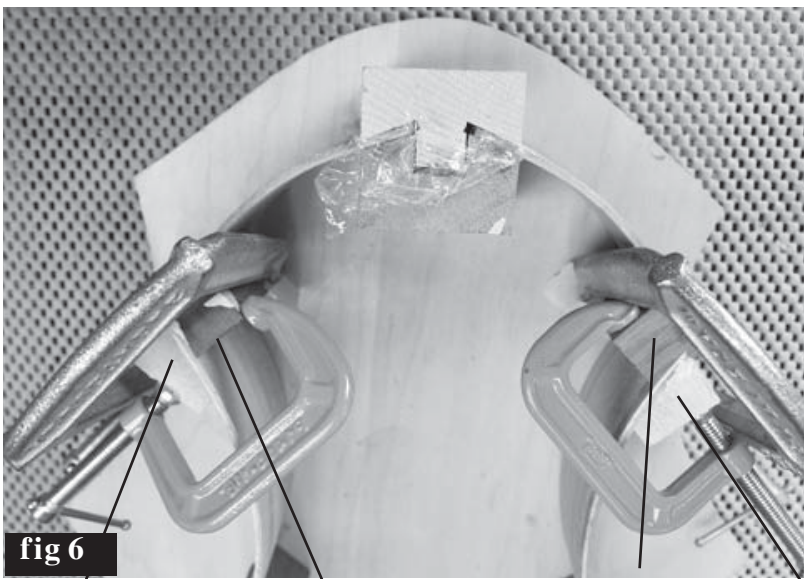

fig 6

clamping wedge      corner block      corner block      clamping wedge

\_\_\_\_ 6. Now you can glue the two mid-ribs into the corners. These ribs should flare outward, as shown (fig 6). They are symmetrical, so it does not matter which end you glue to the first corners. Notice the use of clamping wedges to make it easier to clamp the parts together.

**CAUTION:** It's possible to glue these parts together crooked! Make sure all the parts are pushed firmly into the corner blocks, that the parts remain flush with each other, and that the entire assembly remains flat. Lift the assembly up and look carefully at each seam to make sure it is tightly fit. Also make sure the whole assembly will lay on your flat work surface without rocking.

\_\_\_\_ 7. Continue by gluing the next two corner blocks at the open ends of the mid-ribs, as shown (fig 7).

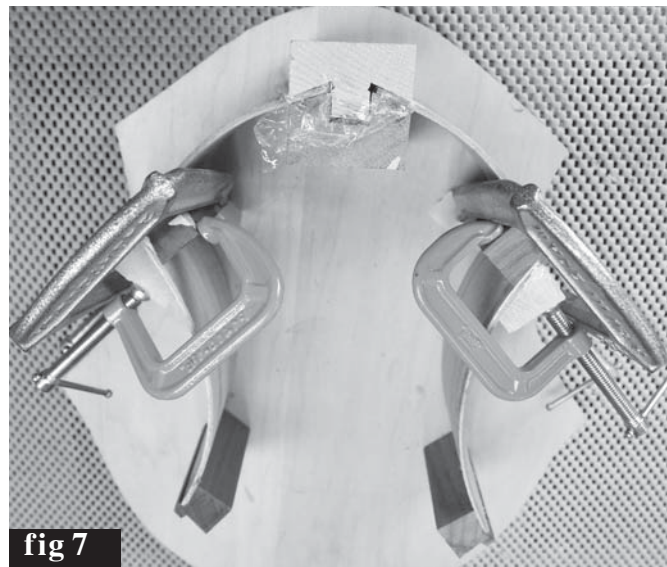

fig 7

8. Glue just one end of the long tail rib to one corner block, as shown (fig 8). Let the entire assembly dry overnight (or 8 hours) before proceeding to close the frame. If you proceed too quickly, the glue is likely to break at one or more of the corners. It takes about 8 hours for most woodworking glue to harden completely.

While you are waiting for this assembly to dry, you can skip to step #34 (page 15) and begin shaping the neck and peghead.

9. When this assembly has fully dried, you can use masking tape to pull the final corner together roughly (fig 9a). Do this WITHOUT GLUE first, just to make sure everything works easily for you, and no corner blocks break free.

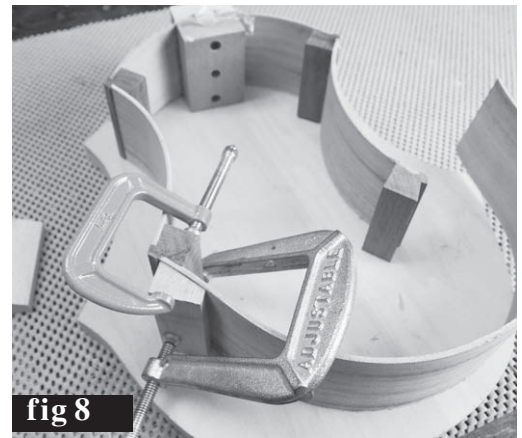

fig 8

Tape a clamping wedge to the joint and then add your clamp, as shown in fig 9b, still without glue.

If the joint comes together correctly, then remove the clamp and tape so you can repeat the process with glue. Allow this joint to dry another 8 hours (because it is under tension).

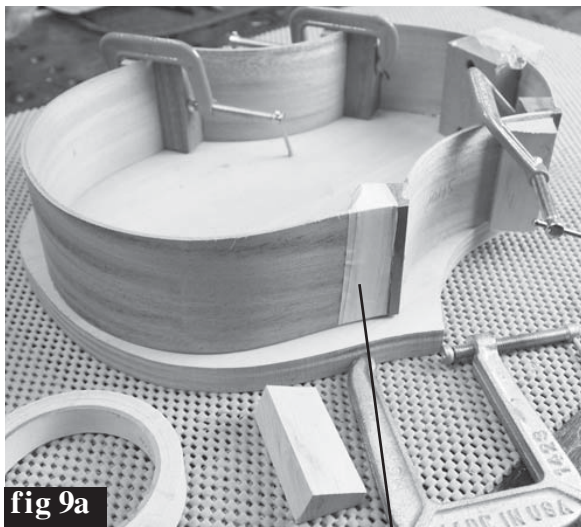

fig 9a

masking tape

While waiting for this last corner to dry, go back to shaping the neck -- it's good to spend time smoothing it to fit your hand.

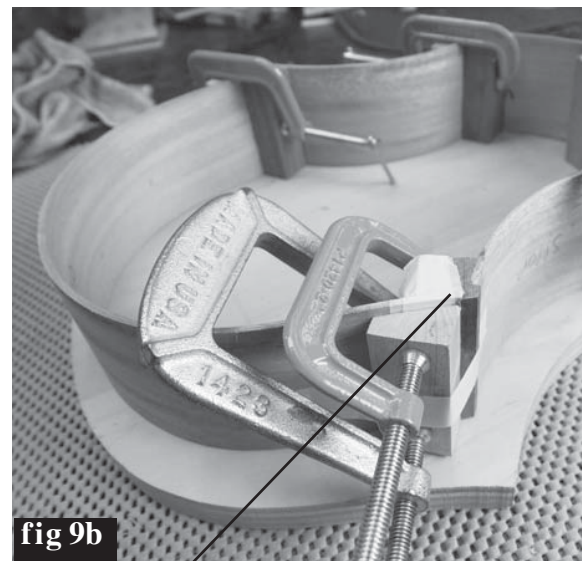

fig 9b

nice tight glue joint

10. When dry enough to remove the last clamp, measure 7-3/8" from each end of the large curved rib and mark it for locating the tail block (fig. 10a). Please note that this may not look exactly centered at this point because the frame may be slightly skewed one way or the other. You'll straighten it in the next step. Glue and clamp the tail block in place as shown in fig 10b.

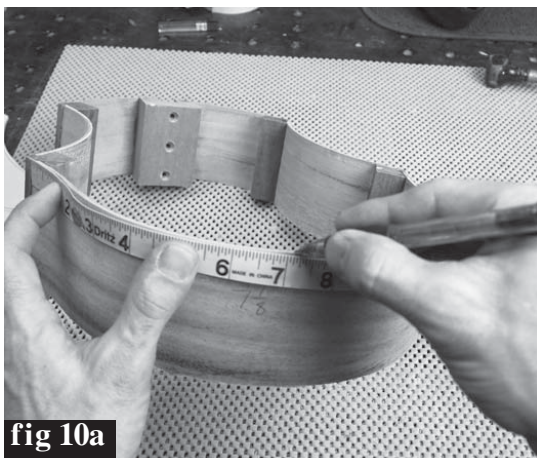

fig 10a

Center the tail block between your marks.

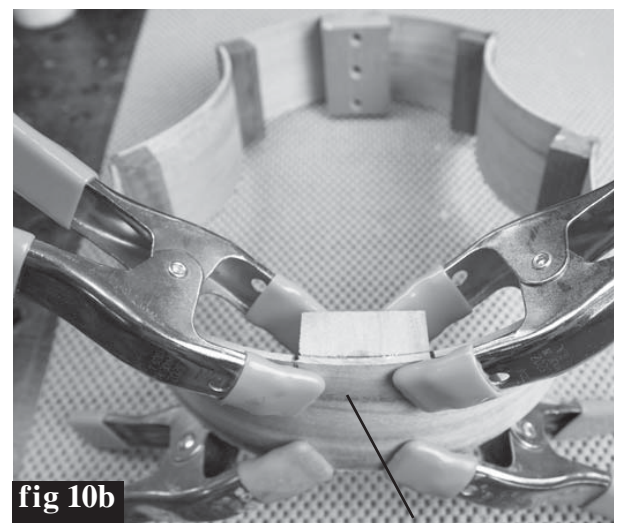

fig 10b

tail block



\_\_\_\_11. Now you need to stretch the frame a little to fit the spacer block between the heel and tail, as shown in fig 11. **DO NOT GLUE THE SPACER!** This is just a temporary piece to hold the instrument in the proper shape until you glue the soundboard in place. You will remove it in step #25. Use clamps to hold each end if necessary.

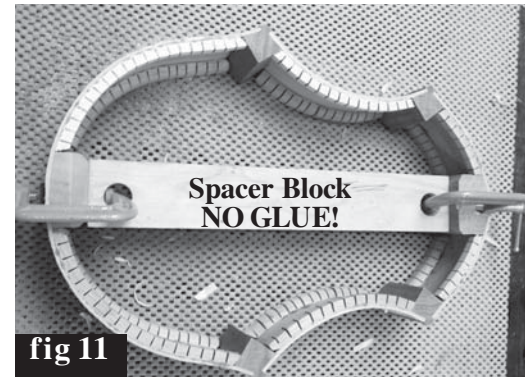

fig 11

## ADDING INNER KERFING

### Tools Required for This Stage

Lots of Spring Clothes Pins (or Small Spring Clamps)  
 Rubber Bands, if needed  
 Wood Glue  
 Damp Rag  
 Sanding Block, 60-80 grit (see fig 13 below)

\_\_\_\_12. Add inner kerfing inside the ribs to provide a wider “shelf” of wood for gluing the front and back panels to the frame. These wood strips are “kerfed” to make them flexible enough to follow the curved ribs.

Cut or break the kerfing into the approximate size needed for each space -- it does not need to fit perfectly (fig. 12a). In fact, it is easier if you cut it slightly shorter than the space so you can easily slide it into position.

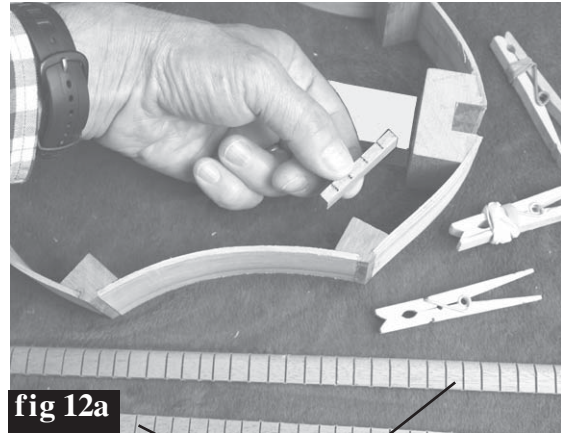

fig 12a

**kerfing flush with edge of rib, or slightly higher**

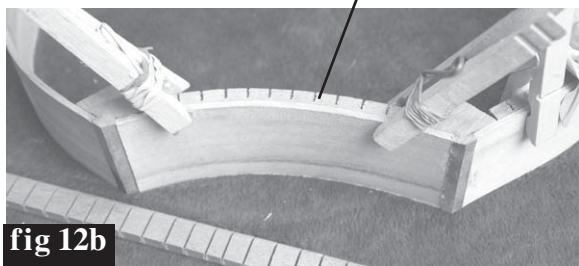

fig 12b

**CAUTION: FLAT EDGE UP!** Pay attention to how you orient the kerfing strips (fig 12b). Keep the flat edge flush with the edge of the rib, or a tad higher, and wipe off excess glue with a damp rag. Try to keep glue off the outside of the ribs, as that will show on the finished instrument.

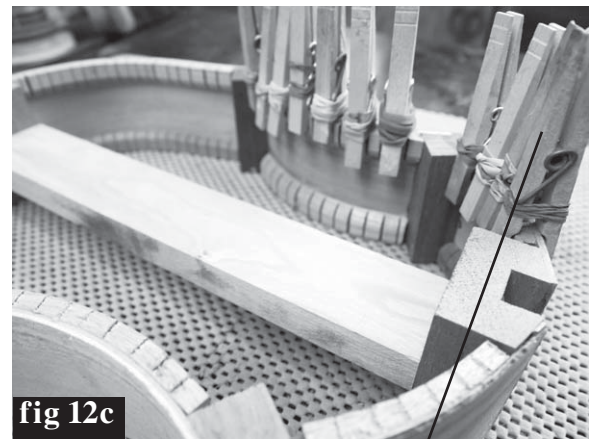

fig 12c

**use plenty of clamps**

Glue and clamp kerfing in place using clothes pins or small spring clamps (fig 12c). It may be helpful to add rubber bands to your clamps to increase clamping pressure. Allow at least 30 minutes for drying before removing clamps.

Glue kerfing around the entire inside frame, on both front and back edges, as shown in fig 12c.

\_\_\_\_13. When the kerfing is dry, make yourself a long sanding block by gluing 60 or 80 grit paper to the face of a straight scrap of wood at least 12 inches long and 3 or 4 inches wide.

This type of sanding block will rest across the frame of the body, allowing you to sand the edges perfectly flat (fig 13). The goal is to remove glue blobs and to sand any high spots down flush with the ribs.

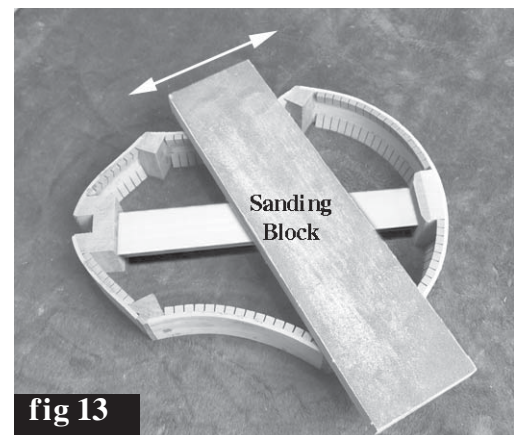

fig 13

## PREPARING THE BACK PANEL

### Tools Required for This Stage

Pencil	Spring Clamps
Wood Glue	Chisel or Razor Knife
Damp Rag	Masking Tape

14. NOW YOU CAN OPEN THE SEALED BAG AND REMOVE THE BACK PANEL (DARKER MAHOGANY PIECE). IF YOU ARE WORKING IN A HUMID ENVIRONMENT, PLEASE STORE THE FRONT PIECE (SOUNDBOARD) IN AN AIR-CONDITIONED (DE-HUMIDIFIED) PLACE UNTIL YOU GET TO STEP #16.

Center the frame of the instrument on the inside face of the back panel and outline the inside edges onto the back panel with a pencil, as shown in fig 14a. Note the center lines at each end of this panel, and the two horizontal lines marking the positions of the inner braces.

Once you have the outline of the instrument on the back panel, you can position the two back braces over the lines marked and check how they fit. If they cross your outline, mark where to trim them so they will not interfere with the kerfing strips inside the frame (fig 14b).

**NOTE: The two back braces are arched on the bottom so that when you clamp them to the back, the back will become arched.**

Use a sharp chisel or razor knife to trim the braces to length. Note: Some builders may prefer to cut little "pockets" (notches) in the kerfing to receive the ends of the braces. That is the more professional method of fitting, but it is more difficult than trimming the braces shorter.

Then you can glue the braces in place, taking care to keep them from sliding out of position under clamping pressure.

**HINT:** Use masking tape to hold the braces in place while you put a clamp at each end (Fig 14c). This will produce an arched back because of the curve in the braces. Double-check the middle to see if you might need to add some weight in the center to achieve a firm glue joint along the entire brace. You can prop the back on a block of wood to support the middle, and then add weights to the center of the braces, if necessary.

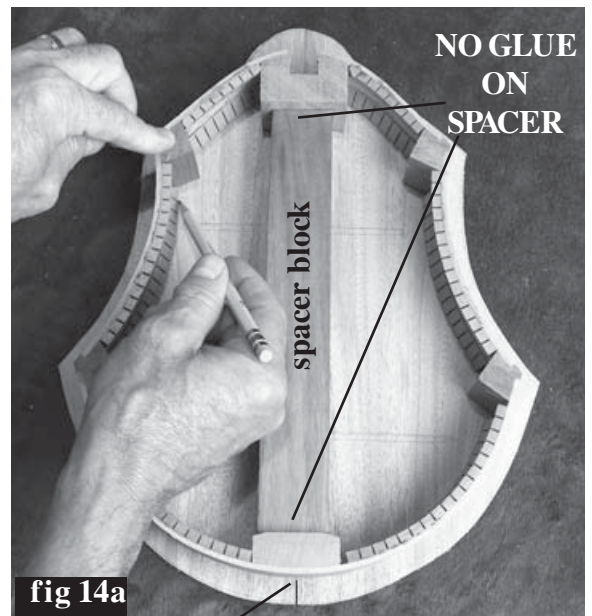

fig 14a

center line

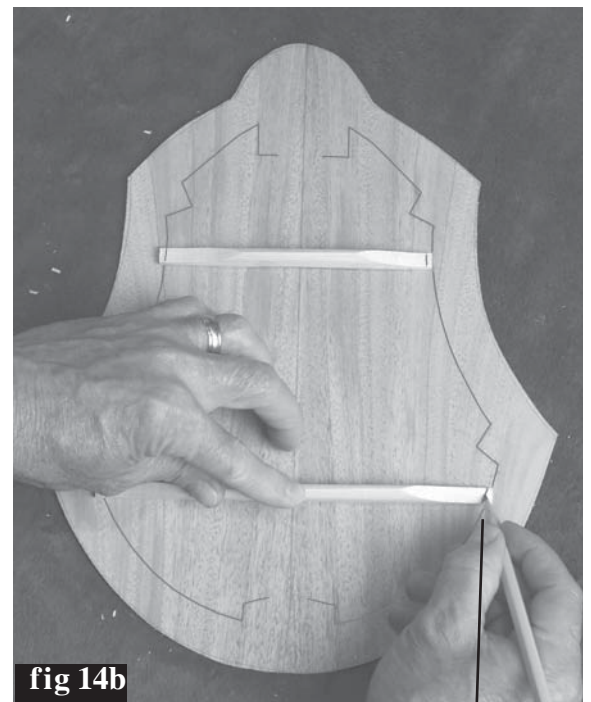

fig 14b

Mark and cut braces to length.

Use tape to keep braces from slipping out of position when adding clamps.

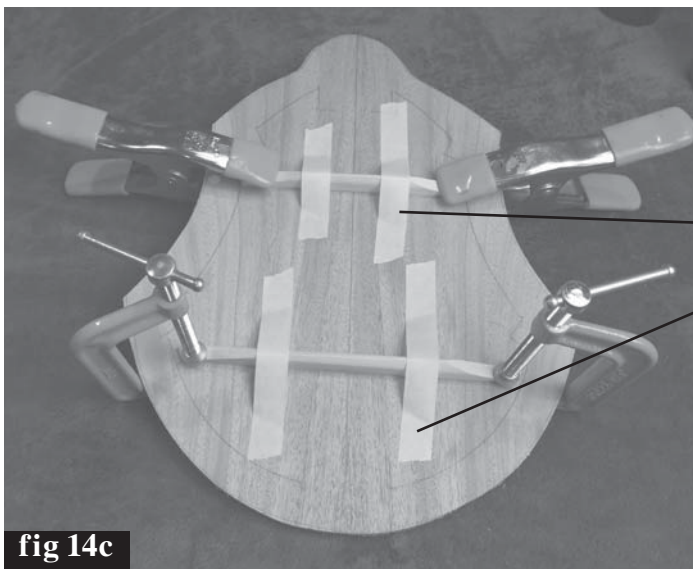

fig 14c

**CAUTION: Don't glue the back to the frame yet! We glue the soundboard in place first (next page).**

Store the back panel in an air-conditioned space until you need it again near the end of the project. That's when you will close the box by installing the back.



# PREPARING THE FRONT (SOUNDBOARD)

## Tools Required for This Stage

Pencil  
Wood Glue  
Damp Rag  
Sandpaper (60-80 grit)

Spring Clamps  
Chisel or Razor Knife  
Masking Tape

\_\_\_\_15. We highly recommend making yourself a clamping pad for the body of the instrument out of 3/4 plywood or particle board (fig 15). Cut it at least the size of the soundboard, or a little larger.

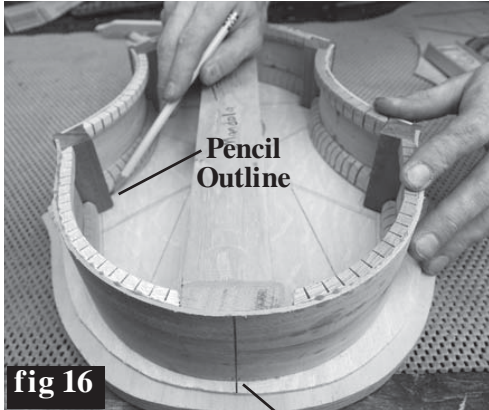

Notice the Center Lines!

## IMPORTANT NOTE ABOUT SOUNDBOARD

The front panel (soundboard) is the lighter colored piece made of solid Sitka Spruce, and has a sound hole cut through it. **If this panel has been exposed to high humidity for more than a few hours, you will need to dry it out in an air-conditioned (de-humidified) room for a few days to shrink the grain. This will help prevent cracks from developing in the future.** Hint: Another easy way to dry it out is to place it in the oven at low heat (200 degrees) for 6-8 hours. Put clean tin foil under it to protect it from any grease on the rack.

\_\_\_\_16. The inside face has pencil marks showing the placement of the braces. Place it on your work table with the inside facing up.

Center the frame of the instrument on the soundboard and outline the interior in pencil (fig 16), just as you did for the back panel. Make certain the frame is centered in relation to the sound hole and the tail end. **Slide the frame up toward the top of the panel to make sure there will be room for the top brace and the "donut" for the rosette.**

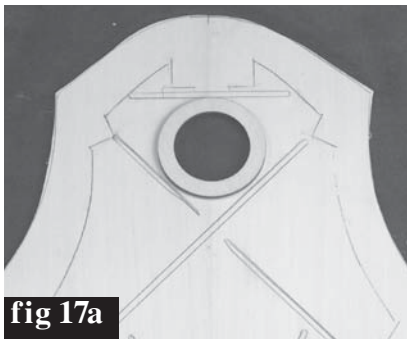

\_\_\_\_17. (OPTIONAL) If you purchased a decorative rosette for the sound hole, you'll need to glue a "donut ring" (fig 17a) inside the sound hole now to provide a ledge for gluing the rosette in place. It is easiest to see the correct position of the donut ring if you look from the outer face of the sound board (fig 17b). Glue this ring to the inside of the soundboard now, before installing the braces.

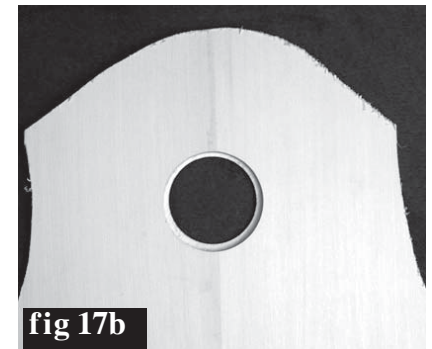

\_\_\_\_18. Find the two braces that are notched to fit together forming an "X" (figs. 18a & 18b). These can be joined two different ways, and we want the longer legs to be spread as wide as they can go (fig 18a). This will give you the maximum bracing strength on the soundboard. Test fit the X to the soundboard, just to be sure you have it correct.



\_\_\_\_19. Position the X braces in place first, without glue, and then arrange the three shorter ones as shown in fig. 19. Trim the ends that are too long, just as you did for the back panel.

When satisfied with the fit, glue and clamp the X braces in place first, making sure to put glue in the joint where they cross. Use clamps and/or weights to hold the X braces in place firmly.

When the X braces are dry, go ahead and glue the other small braces too, as shown in fig 19.





\_\_\_\_ 20. Now you can taper the edges of the X-braces if you like, using a chisel, coarse sandpaper or a sharp knife (fig 20a). We recommend leaving the braces full height for stability, but you can bevel the “shoulders” to lighten them up a little. A lightweight soundboard will sound the best.

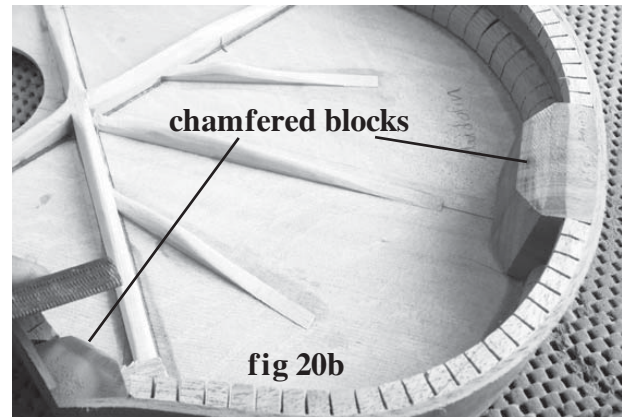

We also like to chamfer (bevel) the inside corners of the corner blocks and the tail block (but NOT the heel block) to give the soundboard a little more room to vibrate (fig 20b). Basically, we like to have about the same amount of glue surface at each corner as there is on the kerfing strips. Use a file or coarse sanding block to do this on both sides (front and back) of the frame to achieve the best sound.

## GLUING FRONT (SOUNDBOARD) TO FRAME

### Tools Required for This Stage

Pencil	6 Clamps (minimum)
Wood Glue	Damp Rag
Clamping Pad (see fig 21a)	

**NOTE:** There is no front or back to the frame until you glue the front to one edge, so you can choose either edge.

\_\_\_\_ 22. Test fit the soundboard to the frame, looking carefully around the entire circumference to make sure the soundboard will make good tight contact with the edges of the ribs all the way around (fig 22).

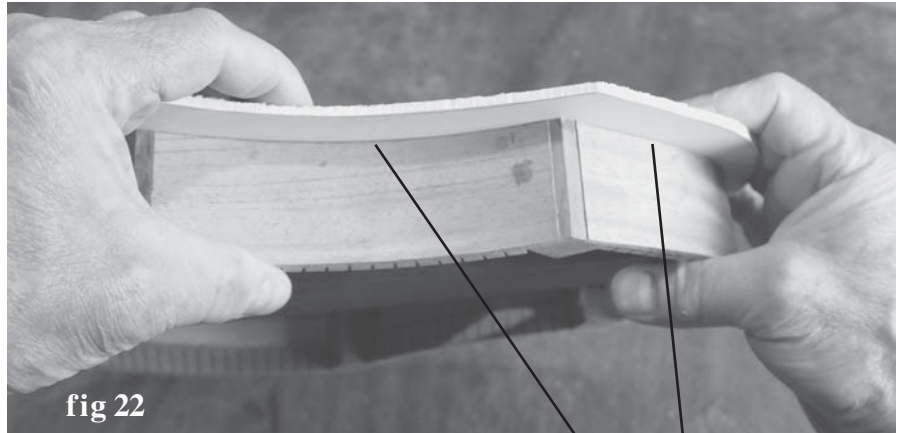

If you find a blob of glue or other irregularity or unevenness that prevents a tight fit, go back to step 12 and use your coarse sanding block to level off the edges of the ribs.

**Tight fit when pressed together**

\_\_\_\_ 23. Continue test-fitting the frame to the soundboard WITHOUT GLUE, carefully lining it up on the center of the soundboard. Leave the spacer block in place for this step so the body maintains the proper length and shape (fig 23).

Take your time here. Darken the center lines on each part, if necessary, so you can easily see when the frame is centered on the front panel.

**Outline the outside of the frame on the soundboard in pencil when you have it positioned where you want it. This will help you re-position quickly when gluing.**

Make sure you have enough clamps to do the gluing job shown in step 24 -- test them to make sure they open far enough and reach in far enough to press the frame down.



**DRY FIT  
FRAME  
TO  
SOUND  
BOARD**

**Line up centerlines**

**NOTE:** We always clamp the frame down against the soundboard, as shown here, rather than placing the soundboard on top of the frame. This leaves everything open and visible while you install the clamps so you double-check for proper alignment as you work. It also ensures that whatever excess glue squeezes out around the edges will not run down the outside surface of the ribs and make a big mess to clean up.

\_\_\_\_24. When you are ready to proceed, squirt a good bead of glue all the way around the frame, including the corner blocks, heel block and tail block, as shown in figure 24a. You want enough glue so that a little excess will squeeze out when the parts are clamped.

Then flip the frame upside down and replace it over the soundboard within the outline you drew in step 23.

Clamp the heel and tail ends first, making sure the center-lines match up. Then put a clamp on each corner piece, as a minimum (fig 24b). If you see areas that need more pressure, add more clamps.

Allow 2 hours for drying before removing clamps.

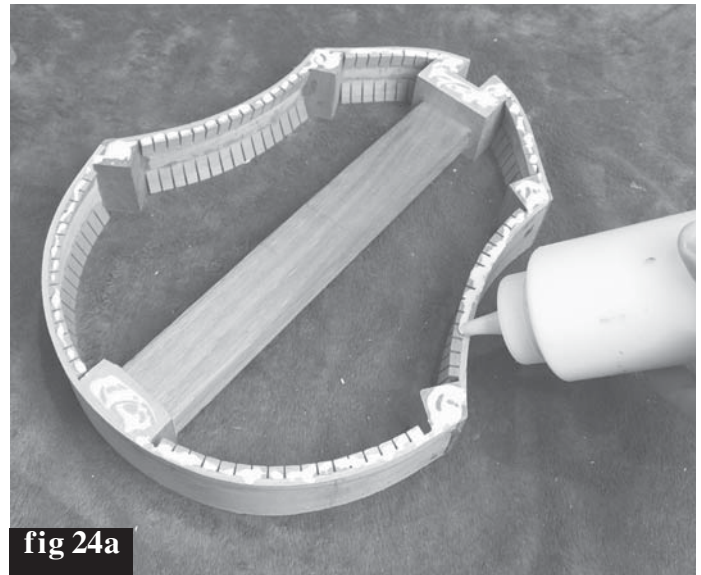

fig 24a

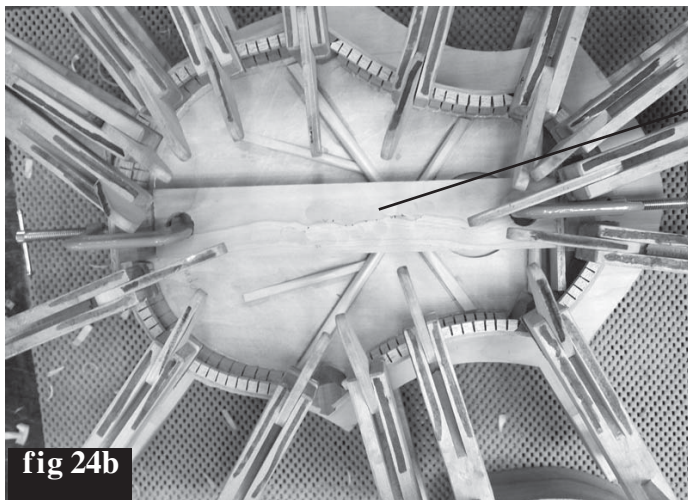

fig 24b

\_\_\_\_25. When this assembly has dried, remove the spacer block and save it for later (Step 41).

\_\_\_\_26. Trimming the excess soundboard material flush with the ribs of the instrument requires some special care. DO NOT attempt to cut off the overhang with a hand-held jigsaw or a coarse hand saw. The spruce wood is fragile, so you must work it carefully.

There are several possible tools for this delicate step, and we'll try to give you some guidance for whichever one you might have available. If you don't have any of these tools, this is a great excuse to go out and buy something!

**OPTION #1: HAND COPING SAW** -- If you are working with just hand tools, a cheap coping saw will cut the excess soundboard very easily. We recommend trimming a little wide, leaving 1/8" or so overhang that can easily be sanding down flush.

**OPTION #2: BAND SAW** -- If you have a bandsaw available, it will do this job very quickly. But be very careful not to cut into the frame of the instrument. A band saw could ruin the whole project in the blink of an eye!

**OPTION #3: BELT SANDER** -- If you have a stationary belt sander, you can sand away the excess soundboard material quite easily. But take care to prevent sanding too deeply -- you could gouge the frame if you are not watching closely.

**OPTION #4: ROUTER** (figs 26a & 26b): This is our preferred trimming tool because it is fast, safe and accurate. Take care, however, to move the router in a clockwise direction around the soundboard (fig 26-b). This is called a "climb cut" because the router bit is pulling the machine that same direction, "climbing" through the wood. If you push the router against the spin of the bit, you will likely chip the soft wood and cause damage to the edges. You don't need a large router for this step, but you can certainly use a larger one than shown here.



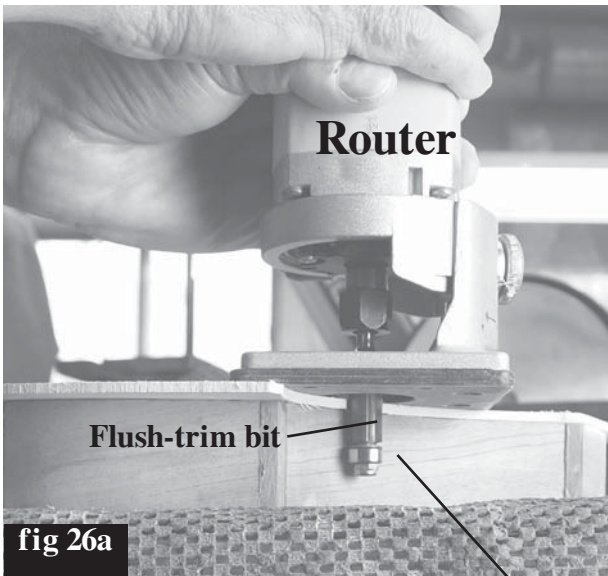

fig 26a

Router  
Flush-trim bit  
Roller bearing follows ribs

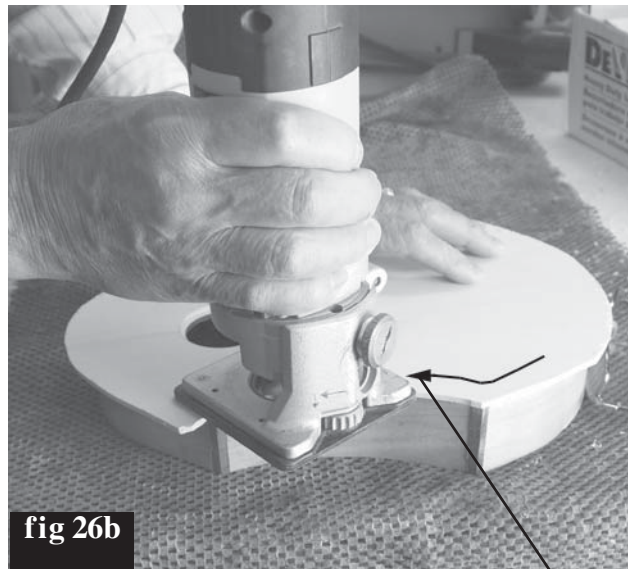

fig 26b

Move router clockwise around instrument, as shown.



fig 26e

### SANDING BLOCKS

Please note that however you trim the soundboard, you will still need to do some careful hand sanding to finish the job. Thankfully, spruce is soft, so it sands quickly with a sanding block.

We recommend gluing sandpaper to a flat piece of wood for sanding the outside curves and taping some sandpaper around a curved item (like a can) for sanding the inside curves (fig 26e). Use coarse sandpaper (60-80 grit) for removing excess wood, and then 100-150 grit for smoothing.

Sand the remaining excess soundboard flush with the sides of the body, as shown in figs 26f and 26g. Make sure the corner blocks are flush and smooth with the ribs too.

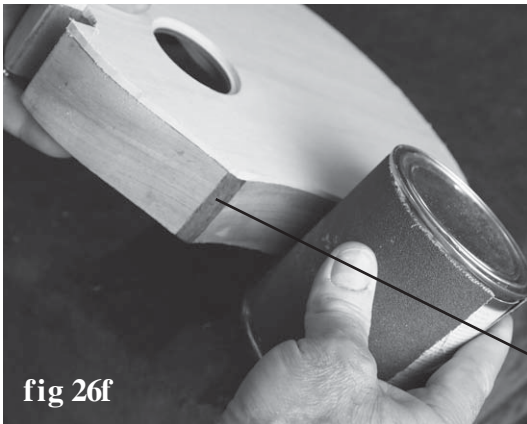

fig 26f

Sand walnut corner blocks flush and smooth too.



fig 26g

**CAUTION:** Be careful to keep the heel square to the top when you are sanding (fig 26h). This will be very important when fitting the neck and fretboard in place later.

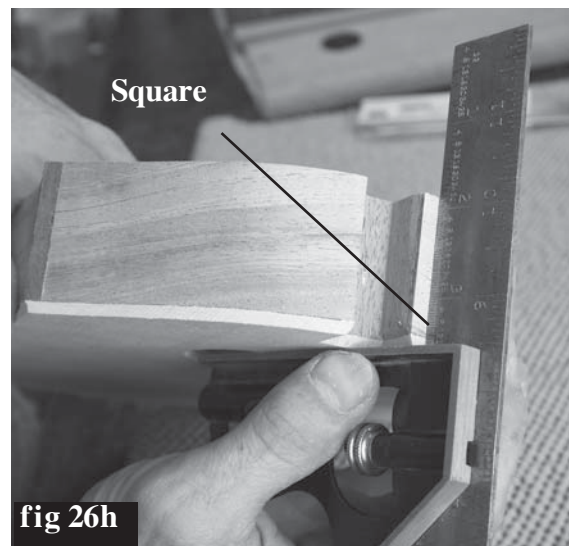

fig 26h

27. Use a flat file or razor knife to finish cleaning out the notch in the heel block, as shown in figures 27a and 27b. Note how we beveled the edges of the spruce top (fig 27b). This will help make sure the neck seats fully into the mortise slot.



fig 27a

beveled  
edges on  
spruce top



fig 27b

## OPTIONAL DECORATION: INLAY BANDING

### Tools Required for This Stage

Pencil  
Router  
Wire Cutter

Razor Knife or Chisel  
Inlay Bit  
Wood Glue  
Damp Rag

Masking Tape  
Sandpaper (150 grit)

28. If you wish to decorate the edges of the soundboard all around the top of the instrument, you will need a router with a small straight bit that can cut a ledge for the inlay strips. A nice inexpensive way to do this is to adapt a 1/2" flush-trim router bit with a 3/8" diameter roller bearing, so the cutters extend 1/16" beyond the roller, as shown in figure 28a. We have these router bits and bearings available on our website at [www.harokit.com/inlays](http://www.harokit.com/inlays).

When you put this bit into your router, you only want the cutting edge to be as far above the router base as the width of your inlay banding (fig 28b).

Be sure to test your cut on a piece of scrap wood first! The router bearing should follow the edge of the wood, and the cutting blades should make a shallow ledge just the right size for the inlay strip (fig 28c).



fig 28a

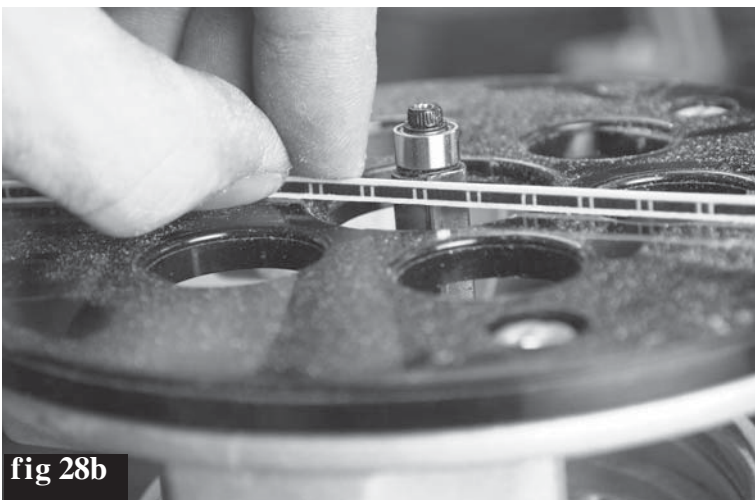

fig 28b

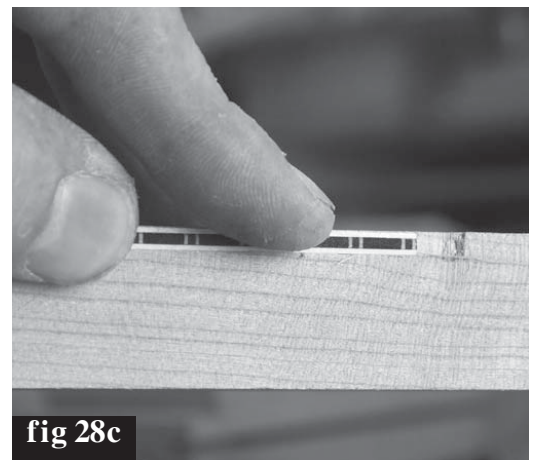

fig 28c



29. When satisfied with the depth of your cut, you can rout a ledge around the circumference of instrument. Make sure to move the router in a **CLOCKWISE** direction, just as you did when flush trimming the spruce soundboard (fig 29).

If your inlay banding is more than 1/8" wide, you will be cutting into the mahogany ribs too. That's just fine. There's plenty of thickness available, and the inner kerfing strips add extra strength to these edges also.

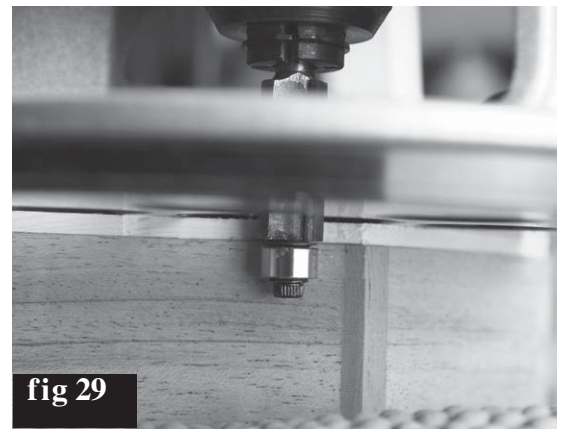

fig 29

30. Once the ledge is cleanly cut all the way around the perimeter, you can begin to install the inlay strips in short sections that are mitered at the corner blocks, as shown in figs 30a and 30b).

Use a sharpened pencil to mark where to cut the strip, drawing the line at an angle that approximately bisects the corner, as shown in fig 30b.



fig 30a

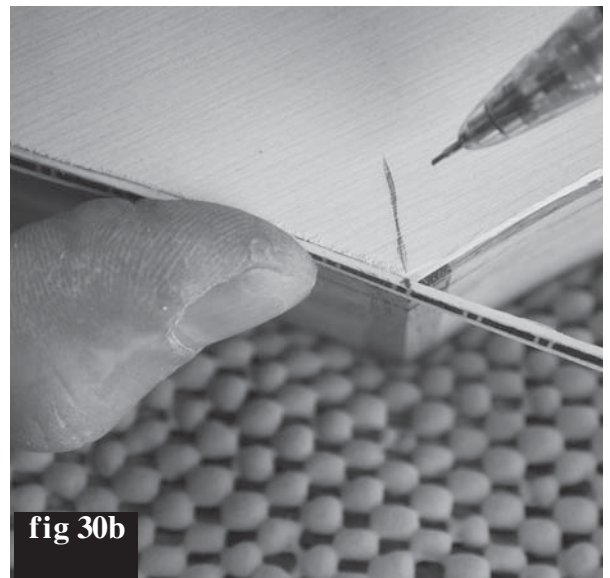

fig 30b

31. Cut the strip a little beyond your mark (fig 31a), then use a razor knife or sharp chisel to make a more precise cut on the line (fig 31b). If you need to change the angle a little or shave it a hair shorter, do that on a sanding block, as shown in fig 31c.

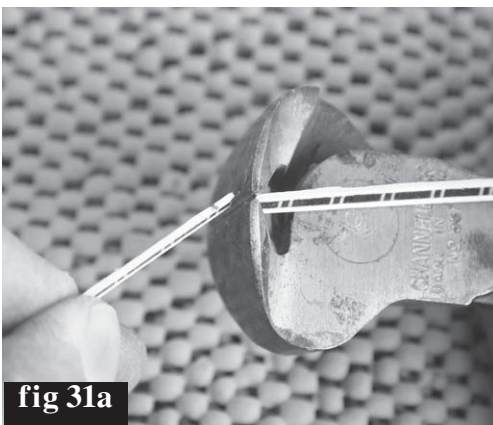

fig 31a



fig 31b

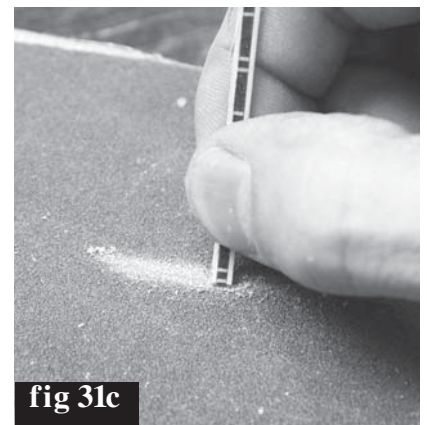
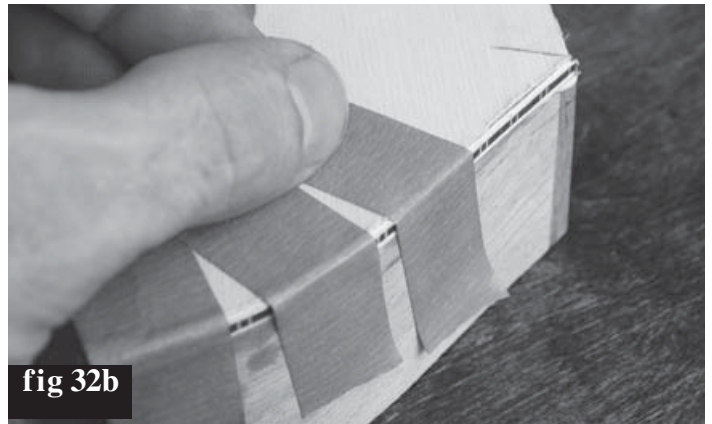

fig 31c

\_\_\_\_ **32.** When you have the first strip ready to install, squirt a thin bead of woodworker's glue into just that short section of the ledge where the strip will fit (fig 32a). Use masking tape to hold the strip tightly in place, as shown in fig 32b.

**HINT:** Pretend the masking tape is elastic -- pull the tape both ways as you press it down against the wood. This will pull the inlay strip all the way into the ledge.



\_\_\_\_ **33.** Now you can fit the next piece of inlay in place, as shown in fig 33a. Notice the pattern of your inlay banding -- your inlays will look the most professional if you trim the end of the second strip to continue the pattern of the first strip (fig 33b). You can make this decoration appear to be seamless if you are careful and patient.



Continue around the instrument in this way, leaving the tape in place for 8 hours before removing. Note that the neck and fingerboard will cover the ends at the heel block, so the strips can stop slightly short of the mortise slot (fig 33c).

Once dry, you'll want to remove the tape and sand the edges clean and smooth, making sure to remove all excess glue that squeezed out around the inlay strips. Don't worry about sanding the inlay strips themselves. The colors go all the way through, so you can clean them up and smooth the surface without removing the pattern. Just don't sand too aggressively on the inlay strips -- they are less than 1/16" thick!

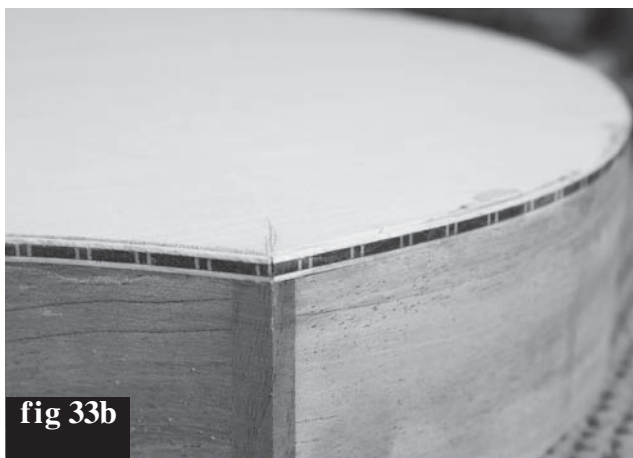



## PREPARING THE FINGERBOARD

### A NOTE ABOUT FRET MARKING DOTS

This kit comes with side markers that you will install along one edge of the fingerboard later (step 58), but we also offer mother-of-pearl dots in our catalog (the 5 mm size is best for a mandolin). If you want to inlay fret-marking dots on the front of the fingerboard, you should do that now, before installing the frets.

**34.** We like cutting the wide end of the fingerboard to make it more interesting, but you can leave it square. Figure 34 shows some other options that are common for mandolin fingerboards. The simplest option is to cut a 3" diameter arc, as shown at left, to mirror the shape of the soundhole. You can use a soup can as a pattern for that.

Make the cuts with a bandsaw and then smooth out the edges with sandpaper.

**NOTE:** Before installing frets, take time to make sure the face of the fretboard is nice and smooth. Sand with progressively finer sandpaper, starting with about 180 or 220 grit. We go all the way to 600 grit to polish the rosewood nicely. You won't be applying finish to the playing surface, so this is your chance to shine it up nicely.



**35.** Trim your fretwire a little longer than necessary to reach across the fingerboard (fig 35a). Then use a light hammer to tap the fret into the slot (figs 35b & 35c).

**HINT:** It helps to place the fingerboard on a very solid surface, such as an anvil or a cement floor. That way the frets will drive in more easily and uniformly. Don't pound too hard, or you will likely distort the fretwire and/or dent the fingerboard.

It is important to seat the frets fully into the slots so the underside of the fret rests on the wood. Use the curve in the wire to your advantage, tapping the middle of the fret home after the ends are in place. That way the arch helps prevent the ends from bending back up out of the slot.

If you over-work a fret, just remove it and use a pair of pliers to restore the shape before making a second attempt.

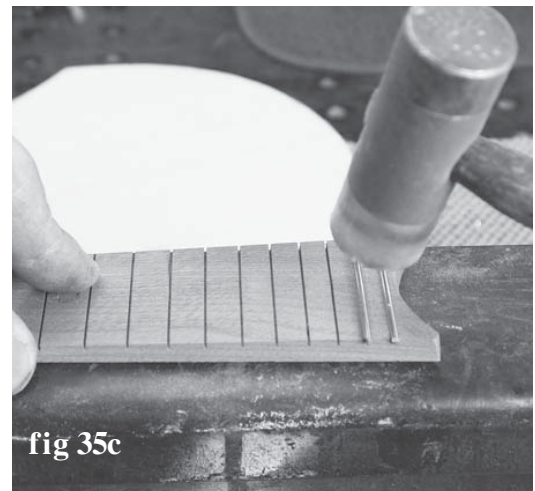
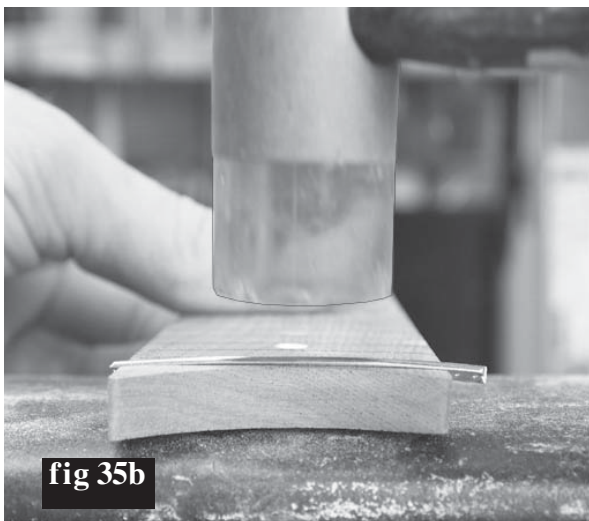
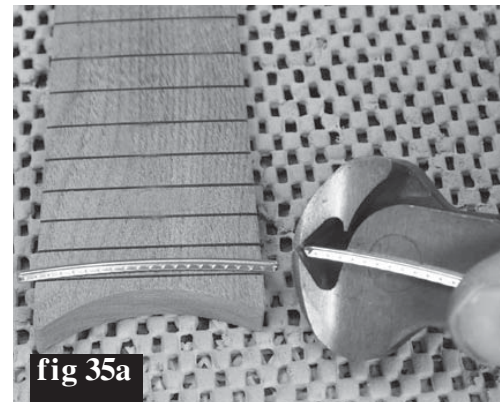

\_\_\_\_ 36. Clip the frets as close to the wood as you can (fig 36a), and then sand the sharp metal ends down flush with the wood. Fretwire is quite soft metal, so you can sand it or file it quite easily. We hold the fingerboard up against a belt sander for this operation, but you can do the job by hand with a flat file (fig 36b) or coarse sanding block (80 - 100 grit). HINT: Cloth-backed sandpaper is stronger than paper-backed types for sanding metal.

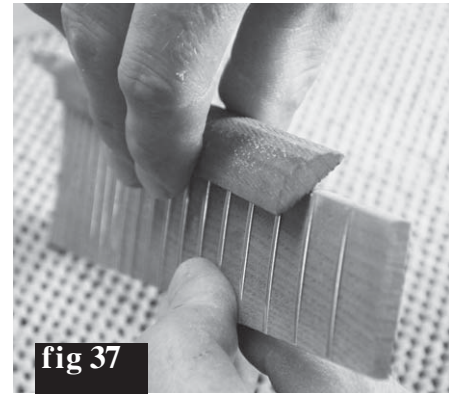
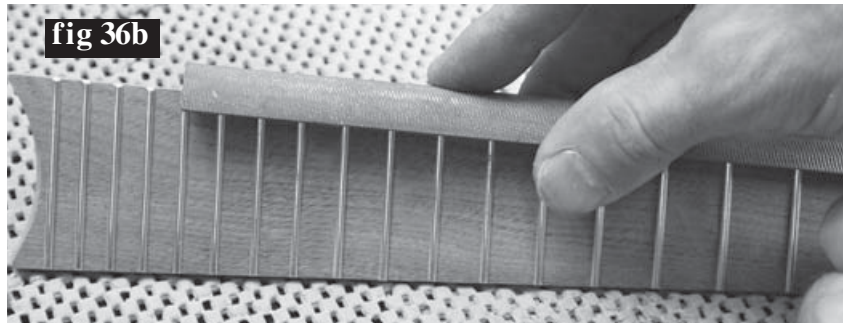
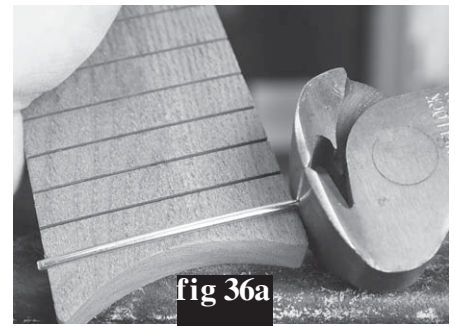

\_\_\_\_ 37. Put a bevel on the ends of the frets by tilting your file to a 45 degree angle, as shown in fig 37. Run your hand along the edges to check for smoothness. It is important to remove all sharp metal ends and make the edges flush and smooth.

## GLUING THE FINGERBOARD TO THE NECK

### Tools Required for This Stage

Pencil	Wood Glue	Sanding Block (150 grit)
Lots of Clamps	Clamping Blocks	Hammer
Damp Rag	Putty Knife	Wire Cutter

\_\_\_\_ 38. Once the fingerboard is done, you can glue it to the neck (we wait on shaping the neck until the fingerboard is attached).

The narrow end of the fingerboard should end about 1/8" before the angle of the peghead, giving just enough flat surface on which to place the nut (fig 38). Hold the parts in place and draw a pencil line on the neck to mark the end of the fingerboard.

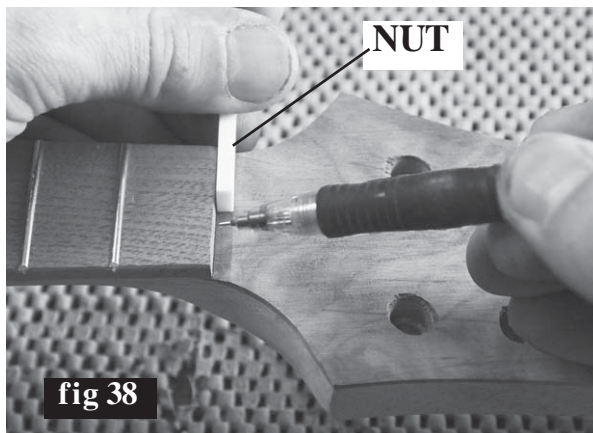

\_\_\_\_ 39. Tap 2 tiny nails partway into the neck, leaving most of the nail standing above the wood, as shown in fig 39a. These will help keep the fingerboard aligned when you glue it to the neck. The exact placement is not critical for these nails.

Then clip off most of the exposed nails, leaving just a short stub poking above the surface of the neck (fig 39b).

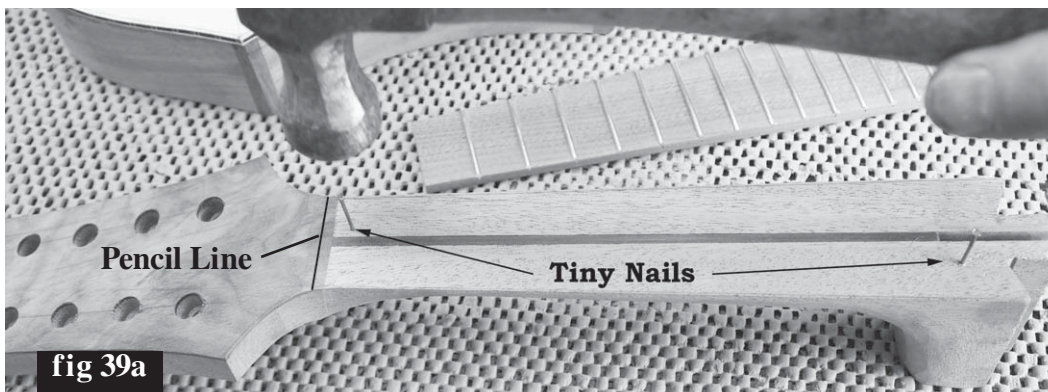



40. Carefully align the fingerboard on the neck, checking that the narrow end matches the pencil line by the peghead, and the sides are aligned with the neck as closely and evenly as possible. Yes, the fingerboard is standing on those two tiny nails! Now press (or tap) the fingerboard over those two nails so the tiny nails punch a depression in the underside of the fingerboard (fig 40a). This will enable you to re-position the fingerboard in exactly the same place after applying glue. The nails will keep the fingerboard from slipping out of place as you apply clamping pressure.

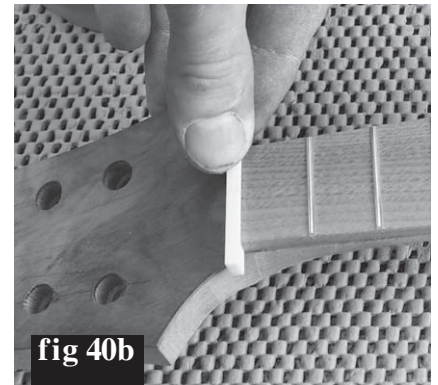
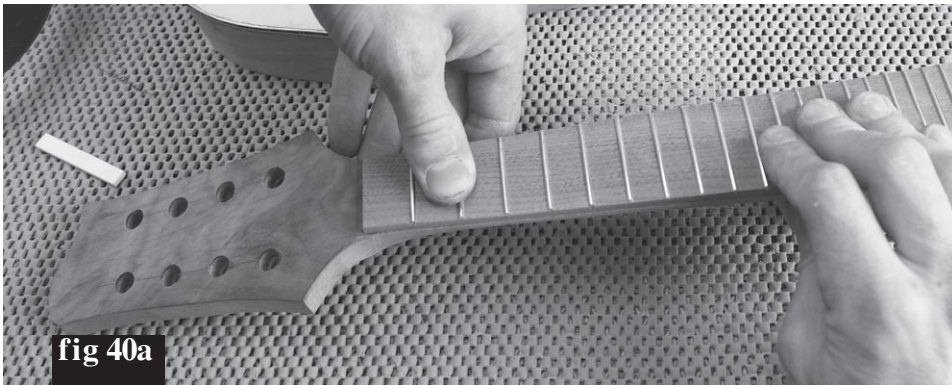

Make sure there is still room for the nut at the end of the fingerboard (fig 40b). It should stand on a little flat shelf next to where the peghead slopes down.

41. Gather a bunch of clamps and scraps of wood to use as clamping blocks before doing any gluing. You want to be well prepared for this step so you don't end up with gaps between the neck and fingerboard. In fact, it would be smart to experiment with your clamping system before applying any glue. You may have different types of clamps than we use, so make sure your system will work well, and have the clamps open to approximately the right size to save time.

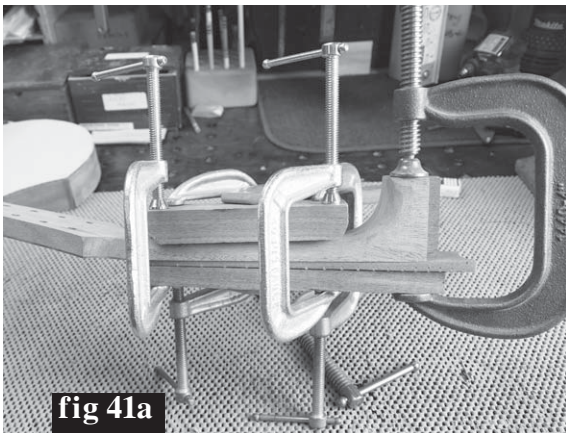

Rehearse installing plenty of clamps by dry-fitting the fingerboard with clamping blocks (fig 41a).

Notice how we use long narrow scraps of wood on each side of the fingerboard to make sure we can press both edges of the fingerboard firmly against the neck (fig 41b).

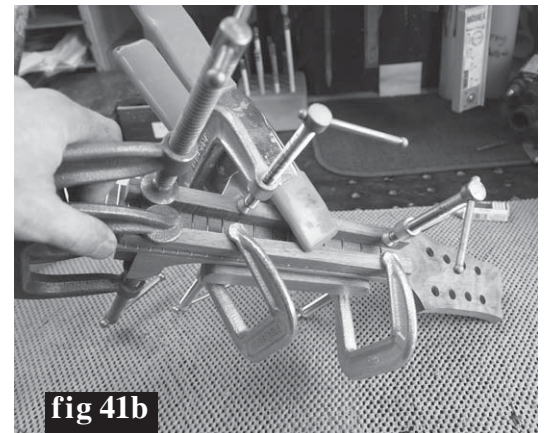

42. When satisfied with your clamping set-up, apply glue to the neck, as shown in fig 42a. Then clamp the fingerboard again and check for any open gaps along the sides. Wrap a damp rag around a putty knife to clean excess glue from the each end of the fingerboard for the nut and the heel joint (fig 42b). Allow 8 hours for drying.





## SHAPING THE ASSEMBLED NECK

### Tools Required for This Stage

Curved File  
Flat file  
Sanding Block (150 grit)  
Drum Sander (optional)  
Razor Knife

\_\_\_\_ 43. We have done basic shaping on the neck for you, but there is some handwork to be done to create the profile you like and for smoothing everything out nicely. We recommend taking your time with this step, checking how the neck feels in your hand for playing. If you have a similar finished instrument available to look at, you can try to copy the same shape on this kit, or you can customize this kit to fit your grip more comfortably.

Some people with large fingers prefer to keep the fingerboard full width, but you can trim it narrower if you like by removing equal amounts of wood from each side.

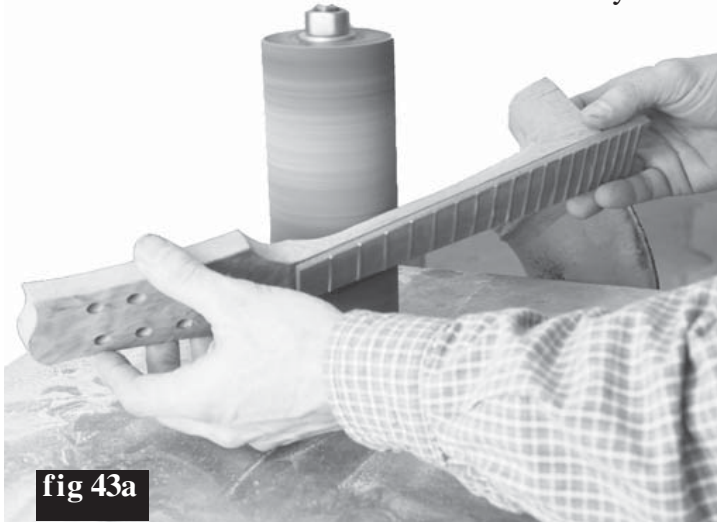

fig 43a

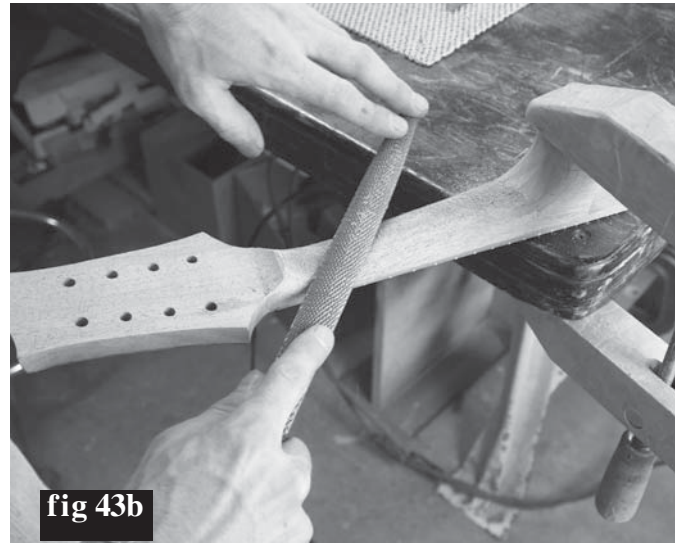
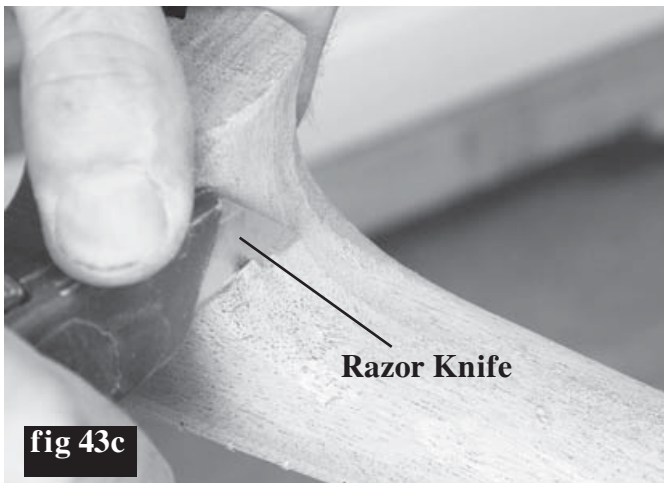

fig 43b



Razor Knife

fig 43c

We use a combination of tools for this process. A 3" drum sander will remove a lot of material quickly (fig 43a), but you'll want to be careful to avoid creating bumps and dips in the wood.

You can do all the shaping without power by using files (fig 43b), sanding blocks, sharp chisels, and/or razor knives (fig 43c).

\_\_\_\_ 44. When the major shaping is done, switch to hand sanding, with the grain, beginning with 80 grit paper and then 150 grit to remove your tool scratches (fig 44).

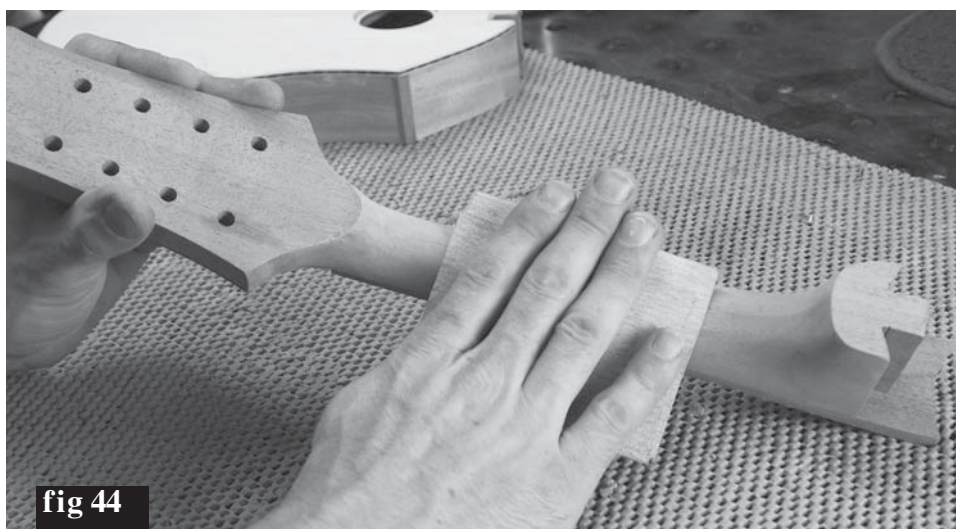

fig 44

### POINT OF INTEREST

People sometimes ask if this instrument has an adjustable truss rod. We build the neck with two well-cured pieces of mahogany for stability, and then we inlay a carbon fiber reinforcement bar down the centerline for added stability. We think this makes a stronger neck than one having a long open slot for an adjustable truss rod.



## FITTING THE NECK TO THE BODY

### Tools Required for This Stage

Electric Drill	7/64" Drill Bit	Masking Tape
Screw Driver	Sanding Block (150 grit)	Ruler
Pencil	Chisel or Razor Knife	Square
Wood Glue	2 Clamps	Clamping Pad

\_\_\_\_ **45.** Test-fit the neck to the body (fig 45). The goal is to have no visible gaps where the neck meets the ribs, and the fingerboard should lay flat on top of the soundboard without bending.



fig 45

Take note that the back is not yet installed, so it is still possible to flex the ribs a little, if necessary, to achieve a good fit here. So before you make drastic adjustments, we recommend installing one wood screw to hold the parts together while you check the alignment of the neck to the body.

\_\_\_\_ **46.** Use the 7/64" drill bit to drill one pilot hole into the neck from inside the body (fig 46a). We put masking tape on the drill bit to mark the length of the screw so we don't drill too deeply!

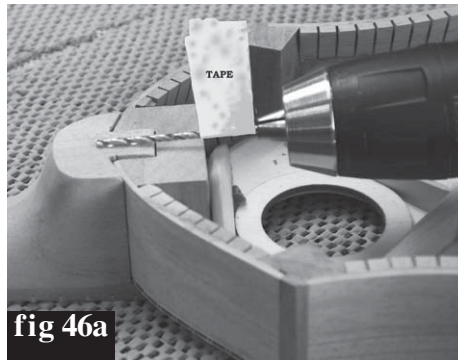

fig 46a

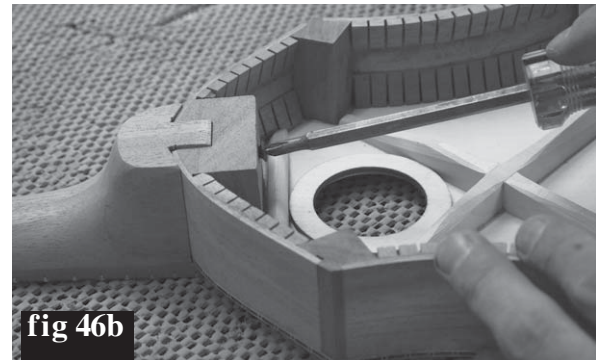

fig 46b

Then use a hand screw driver to install two 1-5/8" wood screws provided. NOTE: We call for a hand screw driver here because you don't want too much power on this screw -- you might strip out the pilot hole in the neck (fig 46b). If you cannot draw the parts together firmly, however, use a power drill very carefully!

\_\_\_\_ **47.** Now flip the instrument over and hold a straight-edge or ruler along each side of the fingerboard so you can trace the path of those edges onto the soundboard with a pencil (fig 47a). Compare those lines with the sound hole and the centerline to see how straight the neck is with the body (fig 47b). The centerline should be centered between the two outer lines.

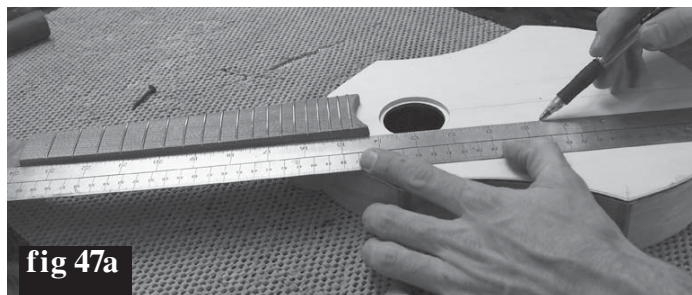

fig 47a

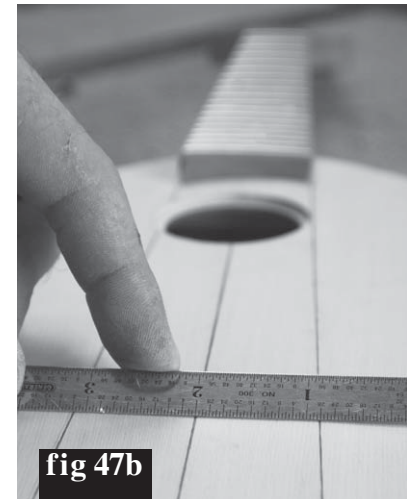

fig 47b

\_\_\_\_ **48.** If you need to tilt the neck one direction or the other to get it aligned with the centerline of the soundboard, mark which side of the heel joint needs sanding. Then remove the neck from the body and sand the surface of that particular rib, using a flat sanding block (fig 48a), and checking to make sure you keep the surface square with the soundboard (fig 48b). Test fit the neck again to see how your efforts paid off. A little trial and error like this should bring the neck into alignment.

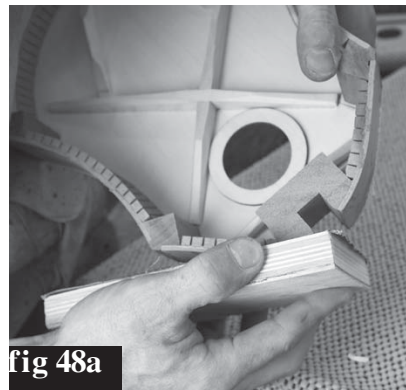

fig 48a

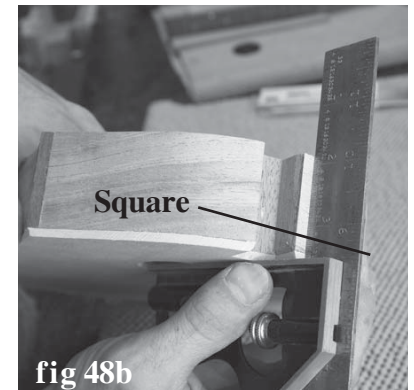
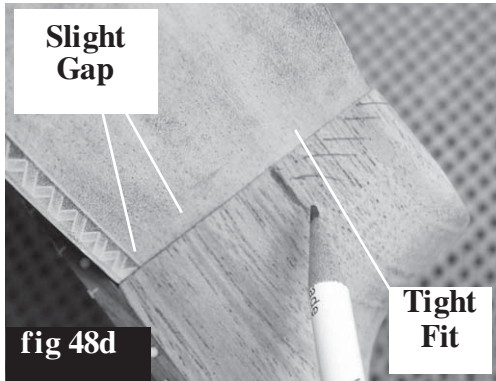
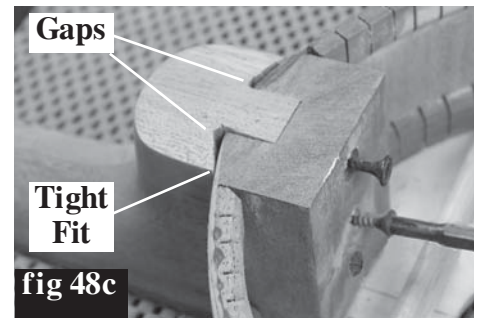

fig 48b

Notice that the neck contacts the body more firmly on the outer edges of the joint than in the center (fig 48c). We design the joint this way on purpose, so it will be easier for you to achieve a nice fit on the outside.

Check carefully along the heel joint to see if there are any gaps showing on the outside (fig 48d), and make pencil marks where you want to remove a little wood so the entire seam closes up nicely. Then use a flat sanding block or file to make very slight adjustments to the outer edge of the heel (fig 50c) until you like the way the parts fit. Be careful not to overwork this. It should only require very light sanding.



Sand the areas where the fit is tight in order to close gaps in other areas.

Check how the fretboard rests on the front too.

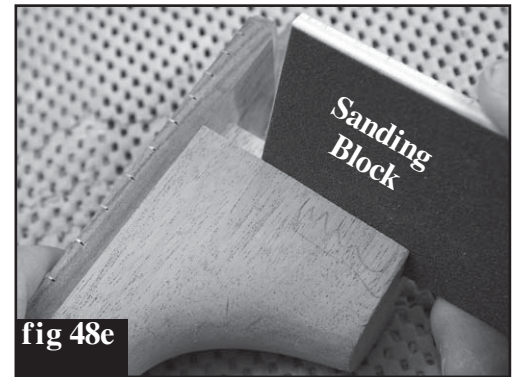

**49.** When satisfied with the fit, you can install the neck permanently with wood glue. Squirt glue on all the contact surfaces: tenon, shoulders of heel, and fingerboard (fig 49a). Install the neck using the same screws (fig 49b).

Then add a couple clamps to hold the fingerboard down fully against the soundboard (fig 49c). Notice the scrap of wood used for preventing the clamps from damaging the fingerboard.

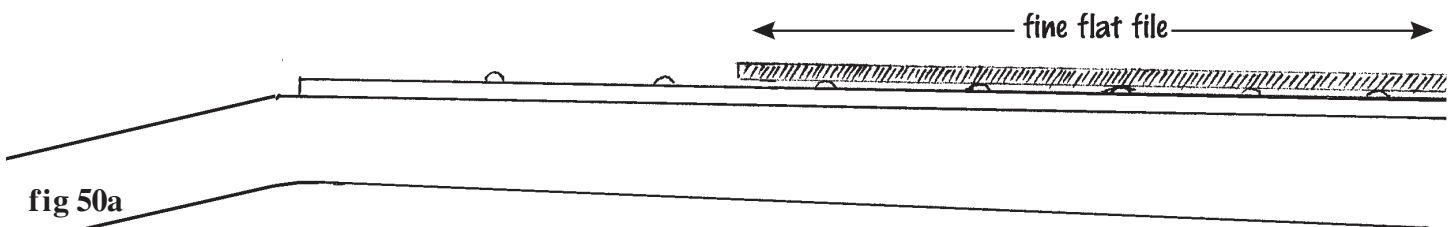
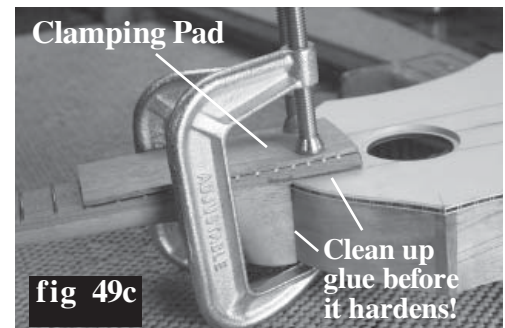
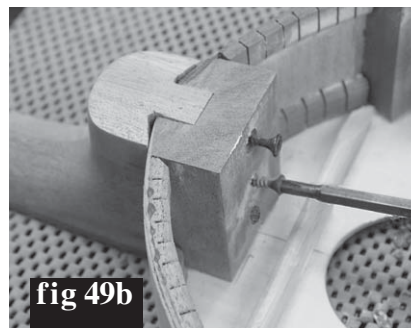
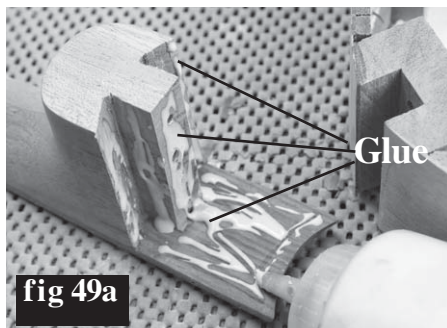

**50.** Now is a good time to “level” the tops of all the frets. Use a large flat mill file, resting on the FRETTS, to wear down any that are too high (fig 50a). Check your progress frequently to see which frets are being cut and which ones are not. As soon as each fret has been scratched lightly with the file, you may consider them all level.

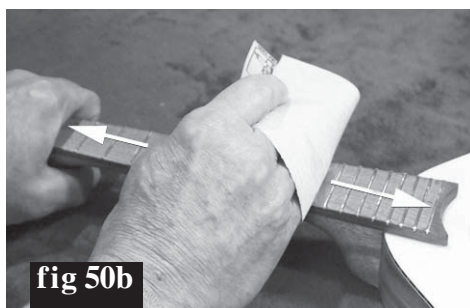

After leveling the tops with a file, you can do a decent job of dressing the frets by wrapping sandpaper around your fingers, as shown in fig 50b. Start with about 180 grit paper, sanding back and forth along the length of the fingerboard. This will help round over the frets again, reducing the flat areas on the frets.

Change to progressively finer sandpaper (say, 300 grit, 400 grit, and then 600 grit) to smooth and polish the frets nicely.



## REINFORCING THE HEEL JOINT

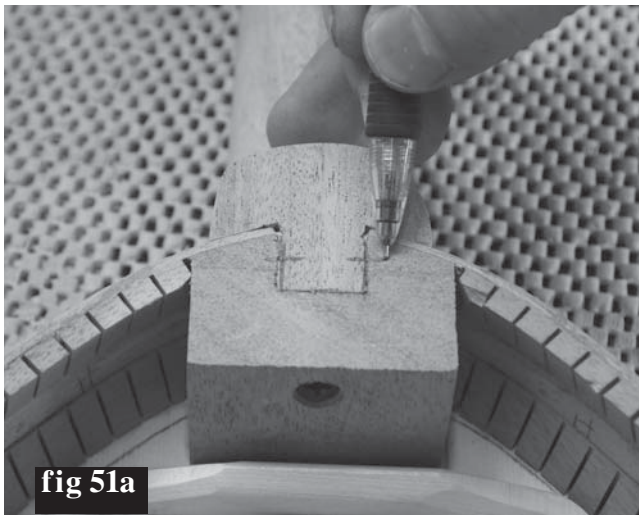

fig 51a

Begin by finding the center of the seams on each side of the tenon, and marking them with a pencil (fig 51a).

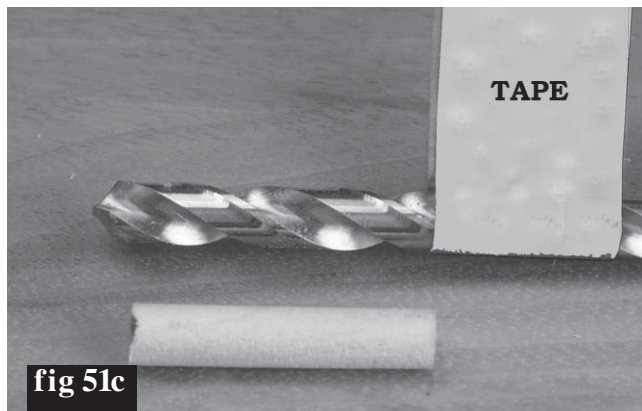

fig 51c

Put masking tape on the 1/4" drill bit to mark the depth of hole you want to drill for the dowels provided (fig 51c). It is best to drill a little deeper than the length of the dowel, just to make it easy to push the dowels in fully.

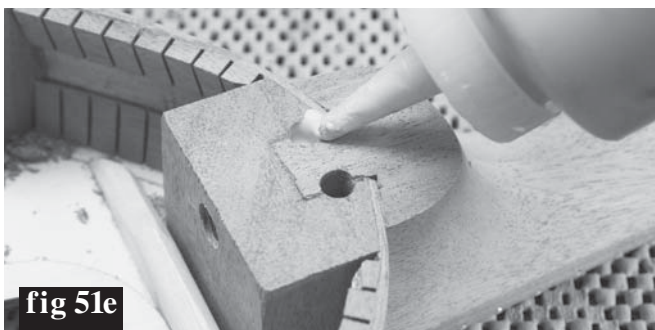

fig 51e

Make sure to get all the sawdust out of the holes. Then squirt some glue into each hole (fig 51e).

### Tools Required for This Stage

Electric Drill	1/4" Drill Bit	Masking Tape
Pencil	Awl	Wood Glue
Chisel or Razor Knife		Long Sanding Block

**51.** Once the glue is dry, remove the screw. It is no longer needed in the joint. We'll show you how to reinforce the joint more permanently here.



fig 51b

Use an awl or nail to punch-mark the center of each seam to guide your drilling (fig 51b).

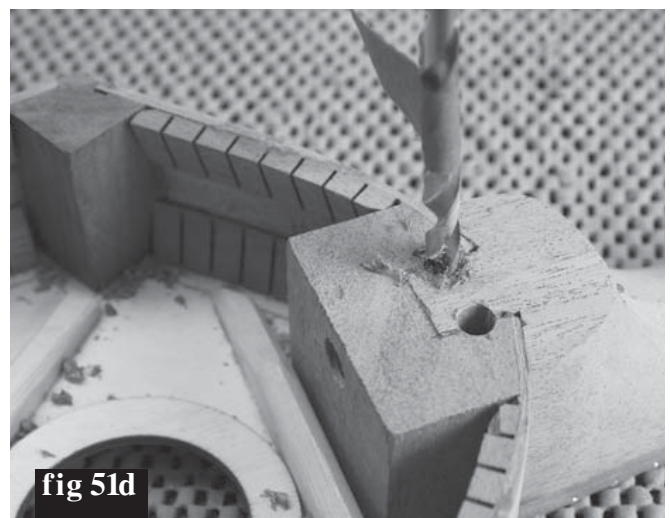
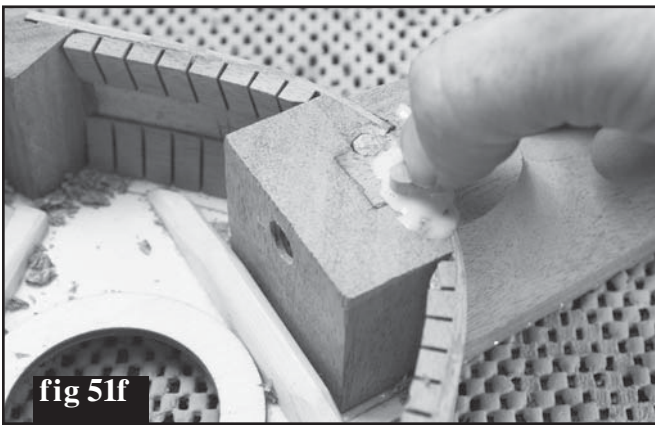

fig 51d

Drill 1/4" diameter holes for the dowels straight into each seam to the depth of your masking tape (51d).



**fig 51f**

Push a dowel fully into each hole until it is flush with the surface of the heel (fig 51f). Use a damp rag to clean up excess glue.

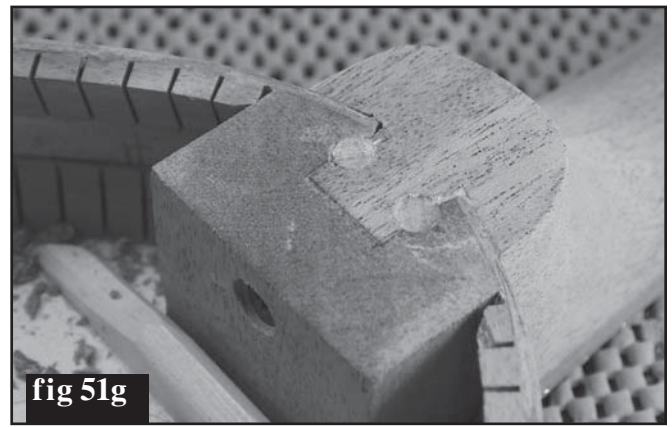

**fig 51g**

If there is a little bit of the dowel sticking up above the surrounding wood, use a sharp chisel or razor knife to carve it down flush (fig 51g).

**52.** Use your long flat sanding block to level the entire back frame of the instrument (fig 52). This will ensure a good fit when you glue the back panel in place.

We use 80 grit sandpaper for this work. Finer sandpaper won't cut well enough to accomplish the task. You need to remove any glue blobs and high points in the kerfing that stand above the edge of the ribs. You may also find that the heel needs sanding down to meet the level of the ribs.

Take your time on this because any gaps between the ribs and back will show on the finished product, unless you plan to install inlay banding around the back.

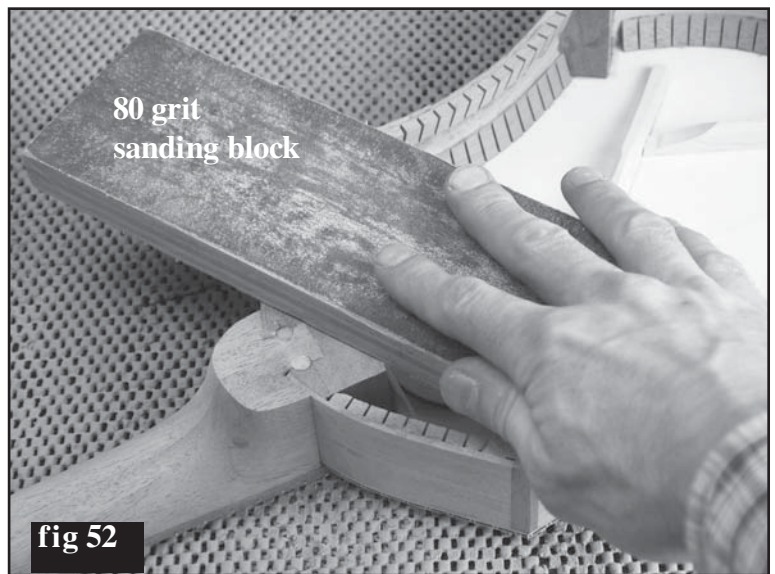

**fig 52**

## INSTALLING THE BACK

### Tools Required for This Stage

Wood Glue	Clamps (at least 8)	Clamping Pads
Router (optional)	Flush Trim Bit (optional)	Coping Saw or Bandsaw
Pencil or Pen	Chisel or Razor Knife	Sanding Blocks

**53.** We always recommend identifying the builder inside the instrument where you can see the inscription through the soundhole (fig 53). You could make a nice label on your computer and print it out on parchment paper, or you can simply write your signature and date directly on the wood with a pen. Practice on a scrap piece of the same wood to make sure your writing will show up nicely.

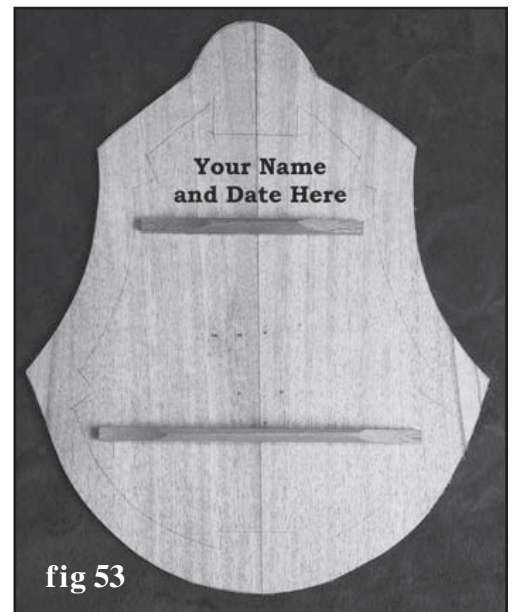

**fig 53**



**54.** Be sure to test-fit the back without glue first, just to make sure you can pull the panel down tightly to the ribs all the way around. **Check your centerlines on these parts too!** You may need to trim the ends of a brace or something in order to align the back perfectly.



When satisfied with the fit, squirt a bead of glue all the way around the perimeter of the frame, as shown in figure 54a. Then use lots of clamps to hold the back to the frame (fig 54b). Be sure to lift the assembly up and look carefully at the seams so make sure the back is making full contact with the ribs all the way around the frame. Allow 8 hours' drying time.

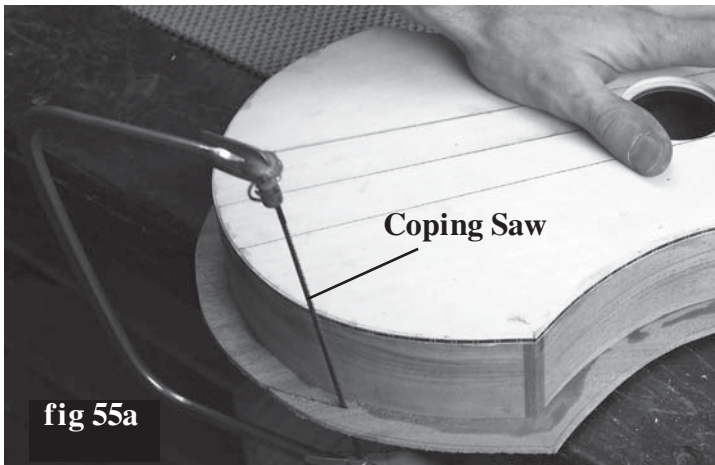

**55.** When the back is dry, you can trim off the excess overhanging material. **DO NOT USE A HAND-HELD POWER JIG SAW** for this work. A coping saw works fine if you don't mind working by hand. (fig 55a).

A band saw works more quickly (fig 55b), but be careful to avoid cutting into the frame. We like to cut a little wide of the frame and then work the rest down by hand, or with a router with a flush trim bit (fig 55c).

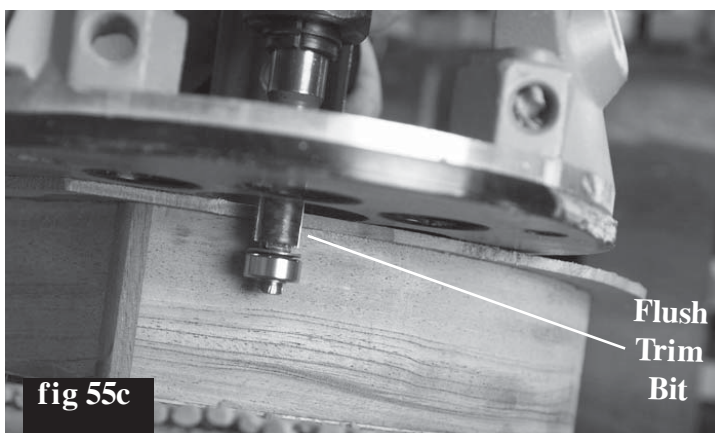

**HINT:** You may need to use a sharp chisel or razor knife to clean up around the heel block where the neck meets the body.

## OPTIONAL DECORATIONS

**56. (OPTIONAL)** If you wish to add inlay banding around the back, now is the time to do it. Inlay banding not only decorates the instrument, but it also covers up gaps you might have overlooked when clamping the back to the frame. You'll need a router and the same inlay bit that you used for the soundboard banding.

PLEASE REFER BACK TO STEPS #28-33 for detailed instructions on installing the inlay banding. The only difference when routing the back is that you will need to stop short of the heel -- don't rout the ledge around the heel (fig 56). You won't be able to bend the inlay banding around the tight curve of the heel. Use a chisel or razor knife to finish cutting the ledge into the corner by hand.

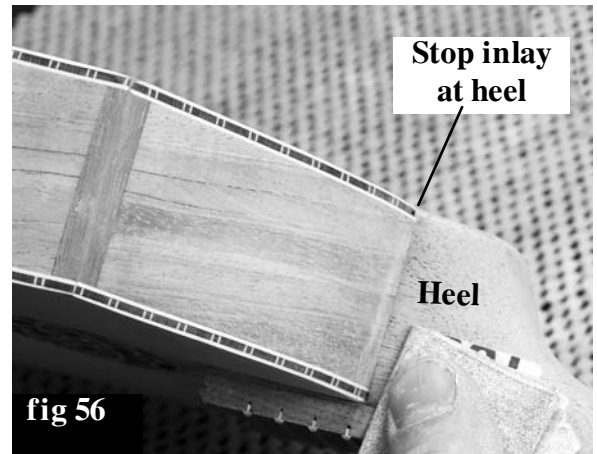

**57. (OPTIONAL)** If you purchased a rosette for decorating the soundhole, this is a good time to install it. If it does not fit easily into the hole, you may need to sand the outer edge of the rosette a little until it fits.

PLEASE NOTE: If you think you might want to install a pickup inside the instrument in the future, then figure out some way to make the rosette removable. Tacky glue or double-stick tape might work well for temporary installation.

Put glue on the exposed ledge of the donut ring, NOT ON THE SOUNDBOARD or the rosette. This will help you keep from making a mess. Take care to orient the rosette pattern so it looks straight on the instrument (fig 57).



**58. (OPTIONAL)** This kit includes a short white plastic rod that can be inlaid along one edge of the fingerboard for marking certain fret positions to guide your playing. This is a good time to install those markers.

These marks should be placed on the edge that faces you as you hold the instrument. Right-handed players will put them along the left edge, as shown in figure 58a. If you expect to play in a left-handed orientation, then just flip the instrument over and count the spaces from the narrow end of the fingerboard (near the peghead).

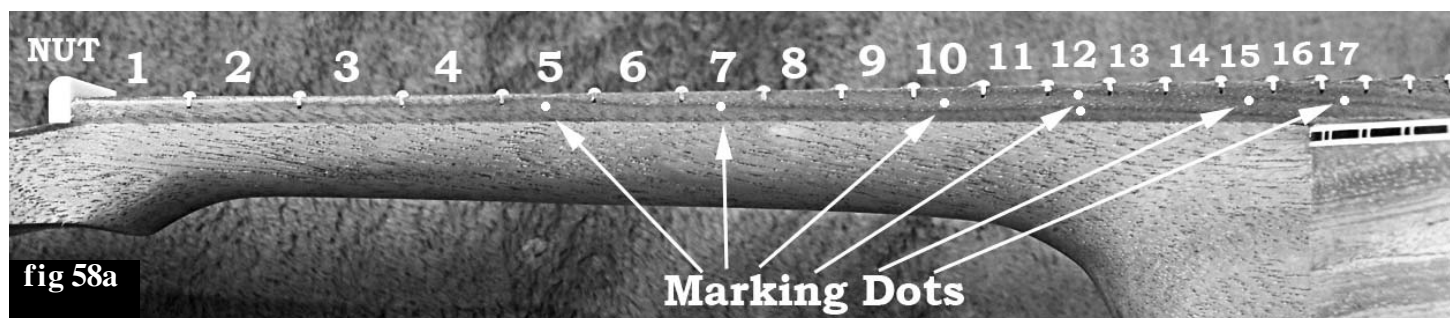

We recommend marking at least 4 spaces (#5, 7, 10 & 12), but you can go further up the scale as shown in fig 58. Notice that we put two dots on the 12th space, as that marks the octave position.

Punch-mark each position first, and then drill carefully with a 5/64" drill bit to a depth of about 1/8" (Fig 58b).

Then you can push the white plastic rod into the hole, clip off the excess, and move on to the next hole. Use a razor knife to trim the plastic flush with the surrounding wood. No need for glue on these markers.





## FINAL SANDING

59. There may be some large areas of the instrument, such as the soundboard and back, that need a quick sanding with a power tool. We use an orbital hand sander with 220-grit sandpaper for a once-over lightly to take care of major scratches and bumps (fig 59a). **BEWARE:** These power sanders can dig major divots in this soft wood if you are not careful. We just use them very sparingly on a project like this....

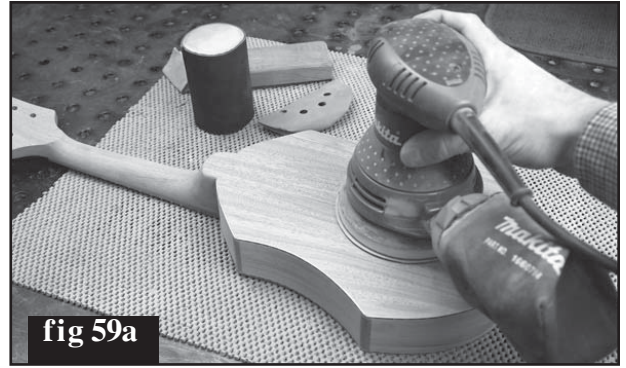

Now it is time to go over the entire instrument **BY HAND WITH SANDPAPER** to clean up all glue spots, machine marks, and other signs of amateur construction. Take your time with this. It helps to have good lighting so you can look carefully for rough spots and glue smudges.

Hand-sanding is often the least favorite part of a wood-working project, so plan a way to make it relaxing and enjoyable. Sit in a comfortable chair by the fireplace with an old towel over your lap to catch the dust. A glass of beer or wine, and some good music will help too.

### DO THIS HANDWORK WITH GOOD LIGHTING!

Begin with 150-180 grit sandpaper, looking for glue blobs, fingerprints, scratches, and machine marks. If you start with sandpaper that is too fine, you'll work and work without making any progress.

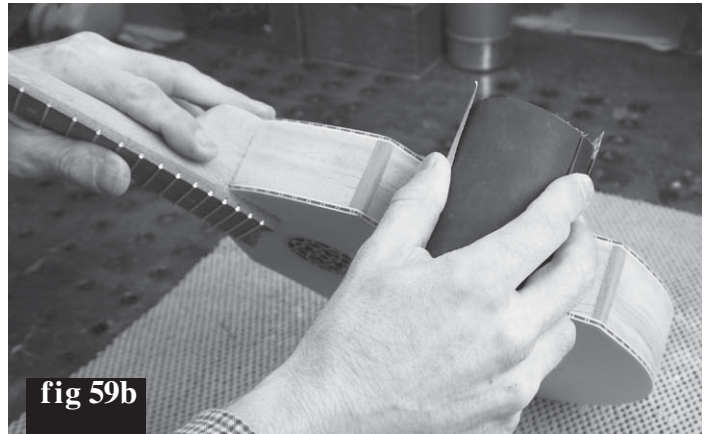

Sand with the grain direction whenever possible. This will give smoother results. The goal is to remove the offensive marks with medium paper, and then switch to finer grit for making everything nice and smooth.

One more thing: A good woodworker knows that a slightly rounded corner always looks and feels better than a very sharp corner. Yes, you can even round the edges of the inlay banding a little bit. It just takes a little sanding at an angle with fine (220-320 grit) sandpaper to make a big difference in how it feels in your hands. **NOTE:** We don't find it necessary to use finer sandpaper than 320 until we are sanding between coats of finish.

OK, that's our little pep talk. Now sit down and do some quality handwork. You'll be glad you did.

## APPLYING THE FINISH

### Tools Required for This Stage

Masking Tape	Razor Knife
Finish of Your Choice	Applicator (brush or rag)
Mineral Spirits	Paper Towels or Rags

60. Before applying finish to the instrument, it is best to cover the playing surface of the fingerboard with masking tape. Rosewood fretboards are usually not finished, except along the edges where you might like seeing the same sheen as you put on the neck. This wood has natural resins for protection from moisture, so additional finish is not necessary and sometimes causes problems by becoming sticky under your fingers as you play.

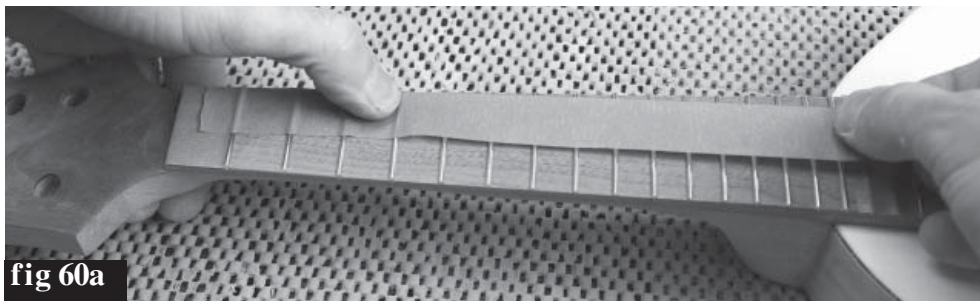

Apply the tape carefully to cover the entire top of the fingerboard, frets and all (fig 60a). Use a razor knife to trim off any tape that hangs over the edges or ends of the fretboard.

Use a clean cloth to wipe off any sanding dust from the wood (fig 60b). Some people buy tack cloth for this purpose, but we just use a clean rag.

Another option is to wet the rag with denatured alcohol (from the hardware store) for cleaning the wood more fully. Alcohol does not raise the grain like water does, and it evaporates quickly, leaving no spots. But this trick is not a necessary step -- just kind of fun to do. The alcohol will give you a preview of the beautiful depth and color of the wood.

Now you are ready to apply the finish. Here are some recommendations:

**STAIN** -- STAINS are coloring agents and should only be used if you dislike the natural color of the wood. We generally discourage people from trying to stain this project because the natural wood grain is so beautiful with a simple clear finish. It is difficult to mask off the soundboard, for instance, and just stain the sides and back of the body because the stain tends to “bleed” under the masking tape. If you are a novice at finishing, or facing a deadline for completion, we especially recommend avoiding stain.

**OIL** -- An oil finish (such as Watco Danish Oil) will give your wood a low luster appearance, bringing out the natural color of the grain, but it tends to soak into the wood and appear dry and “thirsty” after awhile. The principal advantage of an oil finish is that it can be applied and wiped dry immediately, allowing you to proceed to installing hardware (and strings) right away. The disadvantage of oil is that it usually does not give much surface protection or sheen, unless you know how to polish out many coats of gun stock oil.

**POLYURETHANE** -- Any polyurethane will work fine on this project, but we like the solvent-based ones better than water-borne versions. Our all-time favorite is wipe-on Gel Topcoat polyurethane that comes with our Instrument Finishing Kit. It is the product featured below. The advantages of this finish are its simple application (no drips or runs), durability, and deep, soft luster.

**LACQUER** -- Many professional instrument makers still use nitro-cellulose lacquer for their finish. The most readily available lacquer is called Deft Clear Wood Finish. If you choose this product, it is best to purchase a can of liquid to brush on as a sealer coat first, and then use an aerosol can of the same product to spray the final coats. The advantage of this finish is its quick drying time, but the disadvantage is the strong odor and toxic lacquer fumes. **CAUTION:** Lacquer finish may smear some painted decorations or blister some types of decorative decals. If you plan to add paints or decals to your instrument, it would be better to finish with polyurethane instead of lacquer.

So choose your weapon and proceed with finishing all the wood parts. Plan on applying at least three coats of finish. If you don't use our Gel Topcoat, be sure to follow the directions on the can.

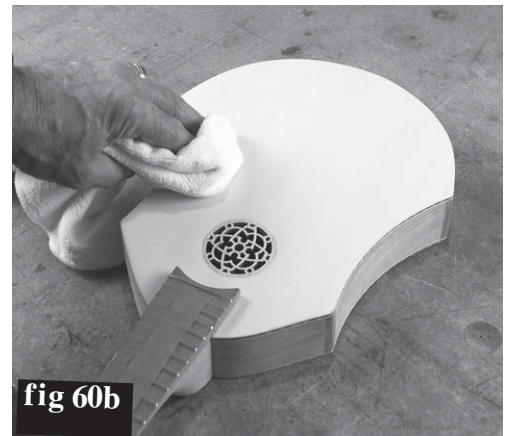

## APPLYING GEL TOPCOAT

**61.** We use a cheap foam applicator to apply the first coat of gel (fig 61a) because the first coat will just soak into the wood anyway. The goal is to get finish into all the nooks and crannies so everything gets covered. No need to worry about brush strokes for this because, if you read below, you'll see that all excess finish must be wiped off.

**DO NOT APPLY A THICK COAT:  
YOU'LL JUST WASTE PRODUCT!**

**NOTE:** The temptation is to create a deep “pool” of finish on the wood right away. Please resist this urge, as it will produce bad results and take forever to dry. The best finishes are applied in very thin coats.





As soon as you have coated the instrument, use paper towels or cloth rags to wipe off all excess finish, right down to the wood (fig 61b). Make sure to wipe the corners too.

Wipe off excess gel from your hands too. Then it won't hurt anything to handle the freshly finished instrument. No need to worry about fingerprints on this first coat.

When satisfied that all the wood has been wetted and wiped, hang the instrument on a nail to dry for at least 8 hours.



**62.** After 8 hours, check to see if the finish is completely dry. If your fingers slide across the surface without “dragging” on damp areas, it should be ready for fine sanding and another coat.

Try sanding lightly with 600 grit paper (fig 62). If the sandpaper loads up with gunk as you sand, then the finish is not dry! Give it more time. (If it takes 3 days to dry, then you either live in a rain forest, or your first coat of finish was too thick....)

Your goal in sanding is to just smooth out the finish -- not sand down to bare wood. So a quick and light sanding should suffice. The 600 grit sandpaper will make the instrument feel very smooth. You will sand this way between coats every time you decide to add another coat of finish.

After sanding, be sure to wipe the surface to remove sanding dust before applying more finish.

**63.** Use a clean cotton cloth (old t-shirt) to apply each successive coat of finish (fig 63). No need for a brush or foam applicator from here on! Now your goal is to apply a very even thin coat to the entire surface. This is not difficult or time-consuming, but you'll need good lighting to see the results as you work. Once you have wetted an area, go back over it with long strokes to smooth the fresh gel.

Here again, you must resist the urge to apply too much finish. Just a thin film is all you want. It may not look like you are accomplishing much, but it will look nicer with each successive coat. Thick coats tend to become uneven, and to take a long time to dry.

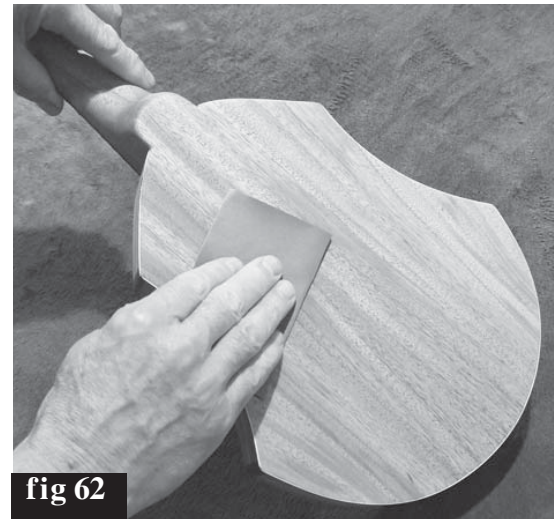

These wiped-on applications will dry more quickly than the first coat because the wood pores are already sealed. If you are working in a warm dry environment, it might be ready for fine sanding again in 3-4 hours. Test it by touch, as mentioned above.

**THAT'S IT!** This is all there is to our simple finishing system. You just repeat step 62 until you like the results. We recommend a minimum of 3 coats of finish to give a good protective seal on the instrument. After that, it's all cosmetics. **NOTE:** If you wish to add other decorations to the instrument (decals, paints, etc.), it is smart to do that work between layers of gel finish. This will seal the decorations permanently to the instrument.



## INSTALLING THE HARDWARE

### Tools Required for This Stage

Masking Tape	Pencil
Electric Drill	1/16" drill bit
#1 Phillips Screwdriver	Masking Tape
CA Glue or Epoxy	Ruler
180 grit Sandpaper	Chisel
Small Triangle File	

**64.** You are finally ready for the final phase! We'll begin by shaping and installing the nut at the end of the fingerboard.

The nut is a little longer than necessary, so if you stand it in place, you can trace the shape of the neck underneath each

end with a sharp pencil (fig 64a). It looks most professional to trim the nut to match the curve of the wood below it.

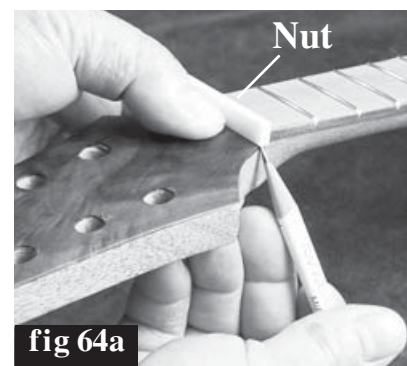

fig 64a

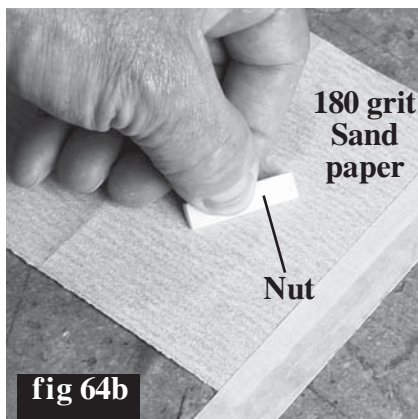

fig 64b

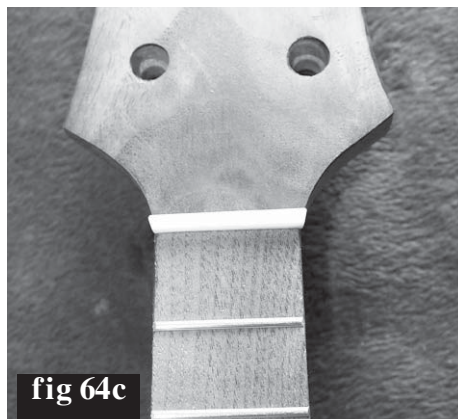

fig 64c

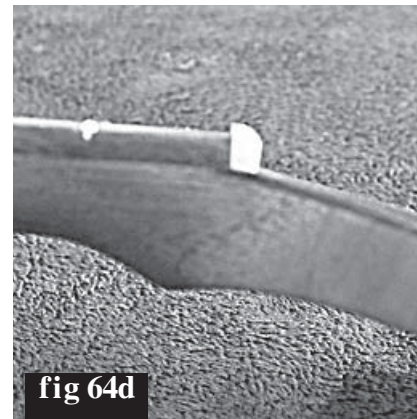

fig 64d

We like to tape a sheet of 180 grit sandpaper to the work table (fig 64b) so you can sand the ends of the nut to your pencil lines, and then round over the top edge that faces the peghead (figs 64c and 64d).

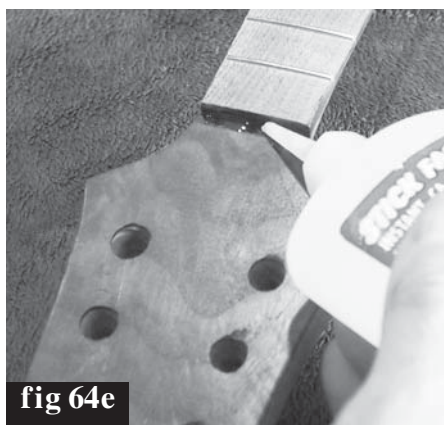

fig 64e

When you have it shaped to your liking, use CA glue or 5-minute epoxy to glue it in place at the end of the fingerboard (fig 64e). We like CA glue because we can just hold the nut in place until it dries (a minute or so).

After the glue hardens, you can use a chisel to chip off any excess that squeezed out onto the peghead (Fig 64f). Glue does not adhere well to a finished surface, so it should be easy to chip off.

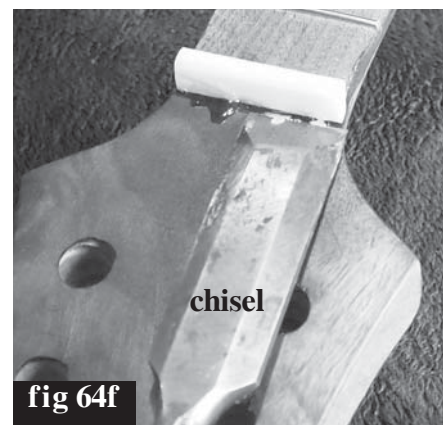

fig 64f

If you goof up on placing the nut, you can just tap it loose, clean off the original glue residue, and try again.

**65.** Find the geared tuners and push them into the back of the peghead, being careful to orient them on the proper sides (fig 65a).

Notice that the buttons with the worm gears are situated closer to the end of the instrument than the posts with ring gears. This is important for longevity and smooth operation of the tuners because we want the string tension to pull the gears together instead of apart over time, keeping them operating smoothly.

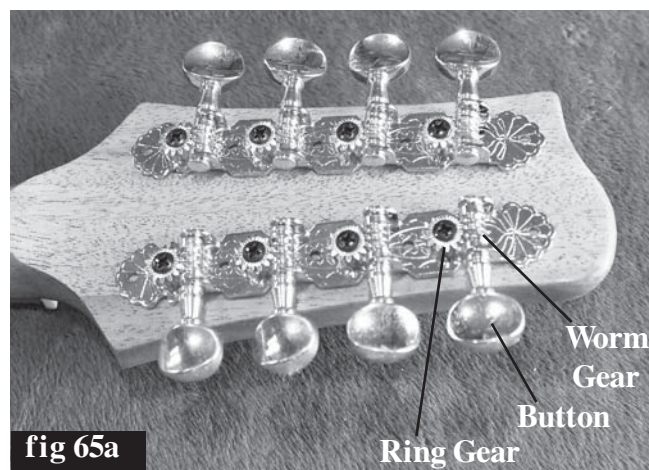

fig 65a



Push the bushings into the holes around the posts on the front side (fig 65b). These fit rather tightly, so you may need to use a small tool to push them in fully.

Use the 1/16" drill bit to make pilot holes for the tiny screws that hold the gear plate firmly to the back side of the peghead. Be careful to drill only as deep as the length of the screws. We like to put tape around the drill bit to mark the maximum depth (fig 65c).

Then install the screws, using a #1 size Phillips screwdriver (fig 65d).

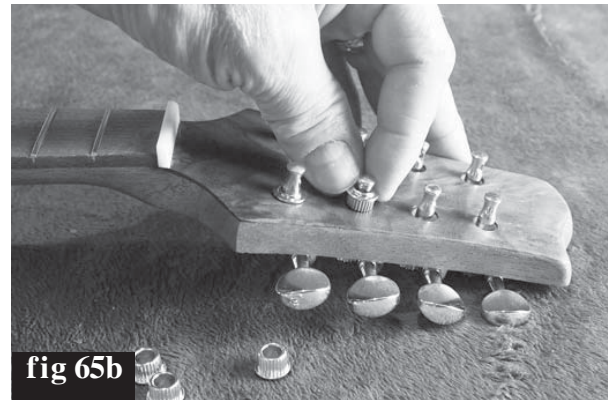

fig 65b

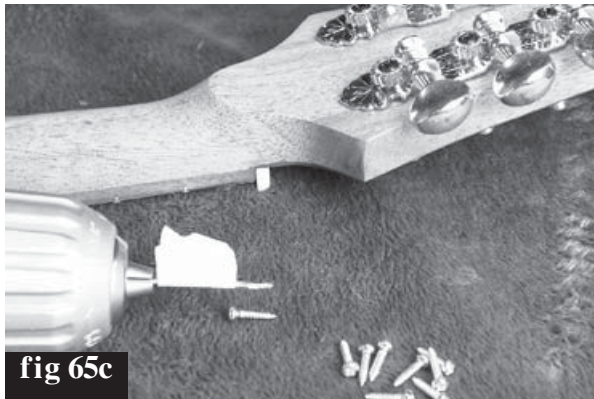

fig 65c

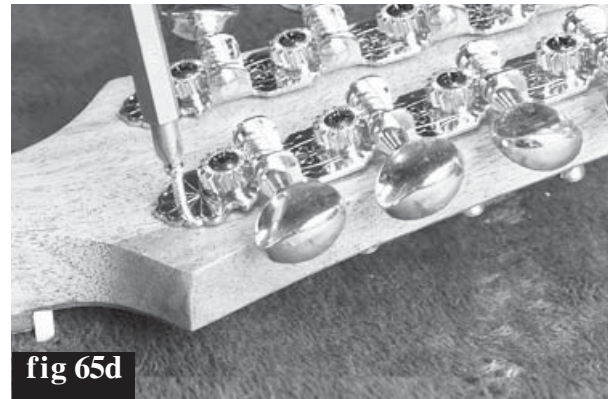

fig 65d

**66.** The easiest way to line up the tail piece with the fingerboard is to hold a straight-edge against each side of the fingerboard and mark its position on a piece of masking tape at the tail end of the soundboard (fig 66a).

This gives you the outside parameters. If you center the tailpiece between those marks, the strings will be nicely centered on the fingerboard (66b).

Use the same 1/16" drill bit to make pilot holes for the screws that hold the tailpiece in place (fig 66c).



fig 66a



fig 66b

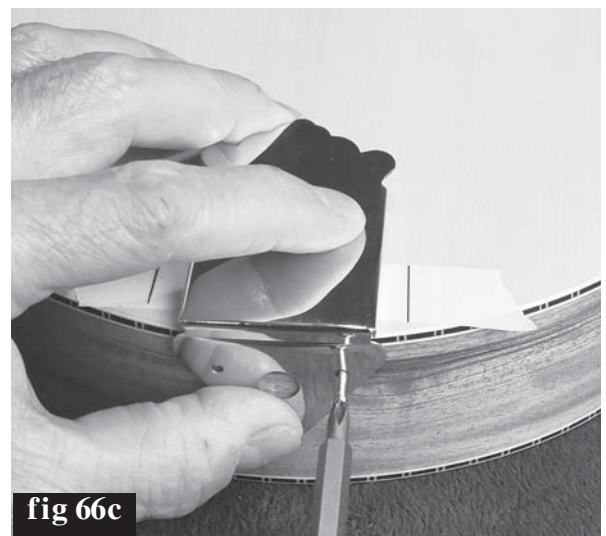

fig 66c

**67.** The Nut and Bridge need to be notched to hold the strings in the proper positions (fig 67a). It is best to use a metric ruler for marking these small measurements, as shown in fig 67b.

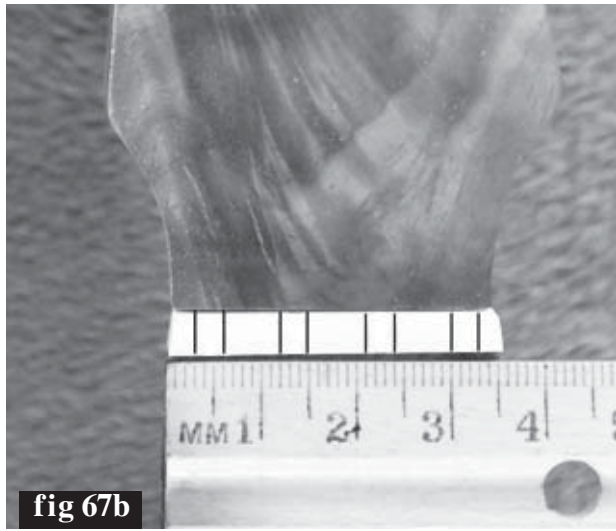

fig 67b

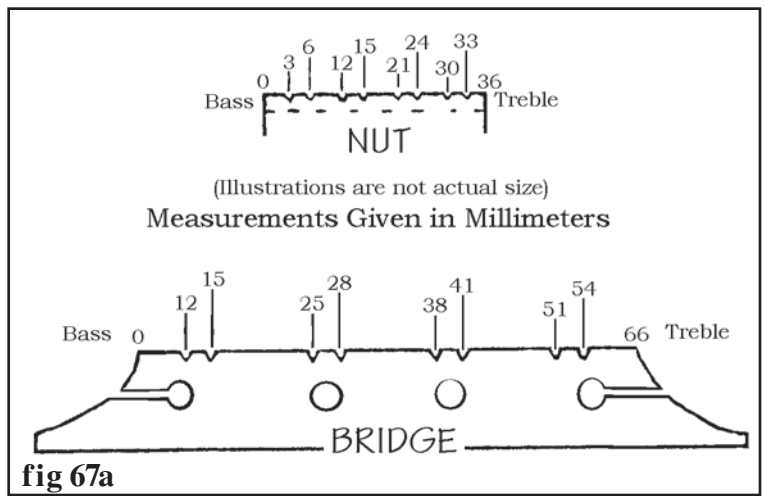

fig 67a

Use a small triangle file for this notching (unless you have nut files to match the string gauges). We bought an inexpensive set of needle files at the hardware, and it includes a nice triangle file for this purpose (fig 67c & 67d). Note that the bass string pairs are separated a little further apart than the treble string pairs because the bass strings are the fatter wound strings.

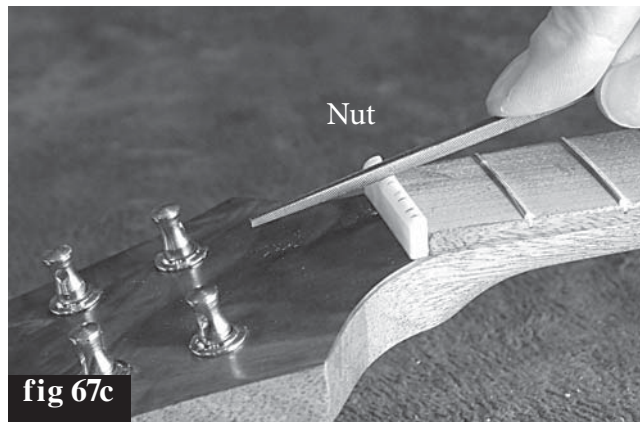

fig 67c



fig 67d

**HINT:** File the notches only about 1 mm deep at first. Once the strings are in place, you may need to file deeper notches to lower the strings, as instructed toward the end of the next step.

**68.** Now you are ready to install the strings! Begin by sliding the smooth metal cover off the back of the tailpiece (fig 68a).

We like to begin with one of the fattest bass C strings and one of the lightest treble A strings, and installing them in the outermost positions on each side of the instrument. These two strings can hold the bridge centered on the instrument, making it a little easier to install the remaining strings, in order.

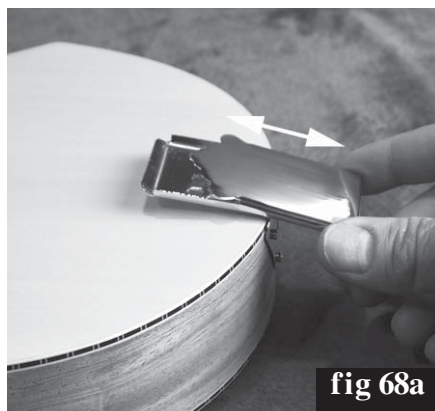

fig 68a

**NOTE:** Your string set has two optional strings included to provide octave tuning at the low C and G positions. If you want to use this option, we suggest placing the plain C and G strings to the left of the wound ones in fig 68b.

Hook the looped end of the string over the proper hook in the tailpiece, as illustrated in fig 68b. Notice that there are some extra hooks aiming sideways on the tailpiece. You can disregard those and just use the eight vertical hooks for your complete string set, as shown.

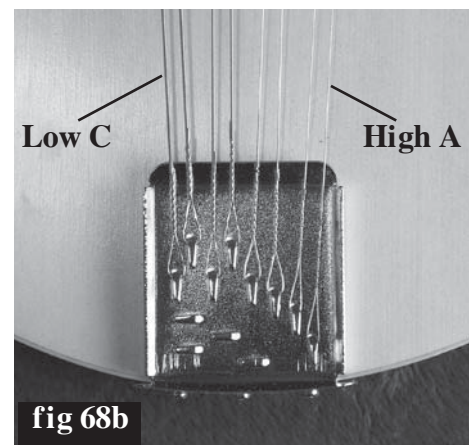
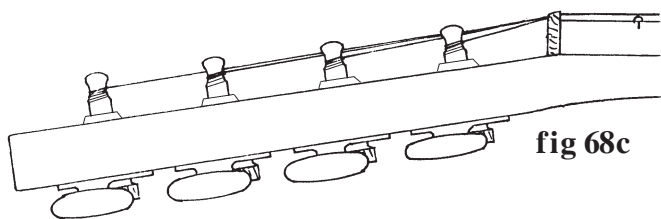

fig 68b





The strings are longer than they need to be, so you can pull most of the slack through the hole in the tuning post before starting to turn the tuning button. Leave enough slack string across the instrument so that there will be 3-4 wraps of string around the post before the string becomes taut (fig 68)c.

**CAUTION:** The correct way to turn the buttons is to make the string fall to the inside of the peghead, as shown in figure 68d. If you don't turn them properly, the strings will rub against neighboring posts and be difficult to tune.

Once the strings are installed, you will likely have some detail work yet ahead to make the instrument easy to play. You want the strings to hang approximately the heights shown in figure 68e. This is called "setting up" the instrument.

**BRIDGE PLACEMENT:** This is a "free-floating" bridge, held in place by the strings. **Position it 17-1/4" from the Nut** and let the first strings hold it there. You can make fine adjustments to the intonation of the instrument after tuning (see back page).

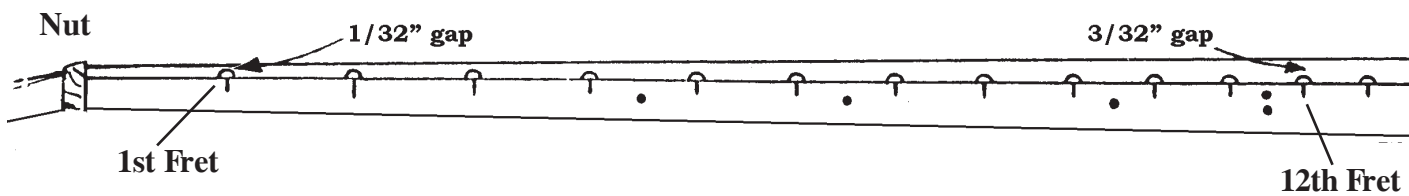
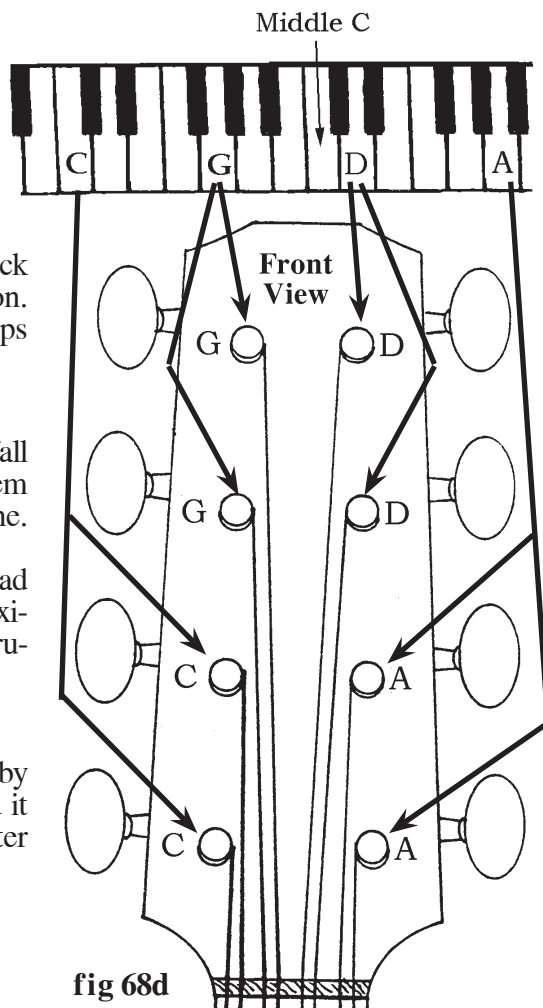

fig 68e

**NOTE: Setting up a new instrument can take several hours, so put on some relaxing music and take your time!**

Start by filing the notches in the nut to get the clearance over the first fret at about 1/32". That means you should just be able to slide a credit card between the string and the first fret. Do this for each string individually.

If you file too deeply, the string will buzz against the first fret. In that case, you'll need to loosen the strings, tap the nut off the instrument and re-glue it with CA glue. Generally, the new glue is enough to raise the nut enough to stop the buzz.

Once you have the proper gap at the first fret, work on filing notches in the bridge to lower the strings at the 12th fret. The 12th fret is the midpoint of the vibrating length, so filing a notch 1/16" deeper in the bridge will lower the string 1/32" (half as much) at the midpoint. If you need more than that much adjustment, it would be easier to sand the bottom of the bridge to lower the overall height of all the strings at once.

Conversely, if all the strings are too low to begin with, the easiest solution is to glue a shim under the bridge to raise all the strings at the same time.

**CONGRATULATIONS!** We hope you have enjoyed building this kit and that you have many years of pleasure from playing it. Please let us know if you have suggestions for improving this project. We often get our best ideas from the customers who build our kits.

# MUSICMAKER'S KITS, INC.

PO BOX 2117  
Stillwater, MN 55082

651-439-9120  
www.harokit.com



## FINE ADJUSTMENTS

You may find the 17-1/4" bridge location to be slightly off for good intonation in the highest frets. This is caused by the amount of stretching required of the strings when they are pushed down against the frets. You can correct for this as follows, using an electronic tuner for checking accurate pitches:

Check the pitch of each string at the 12th fret to make sure they sound exactly one octave above the open string.

If the fretted pitch is slightly higher than an octave, slide the bridge back toward the tail piece a little bit.

If the 12th fret pitch is slightly lower than a perfect octave, then slide the bridge up a little bit toward the soundhole.

If you'd like to install a strap on the instrument, we have straps and mounting buttons available at Musicmakers. The mounting buttons can be positioned as shown in figure 69, with one button replacing the bottom screw on the tailpiece, and the other resting on the curved heel of the neck.

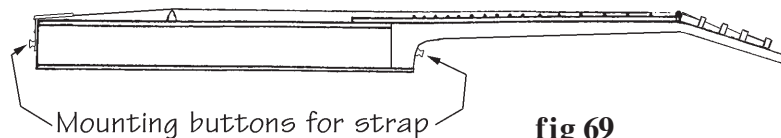

Mounting buttons for strap

fig 69